



SM88

(300 Series)

Four Post Surface Mounted Lift

Capacity 4,000 kg. (8800 lbs.)

Maximum Axle Load 2680 kg. (5900 lbs.)

Maximum Wheelbases of 4636mm (182-1/2") & 4026mm (158-1/2")

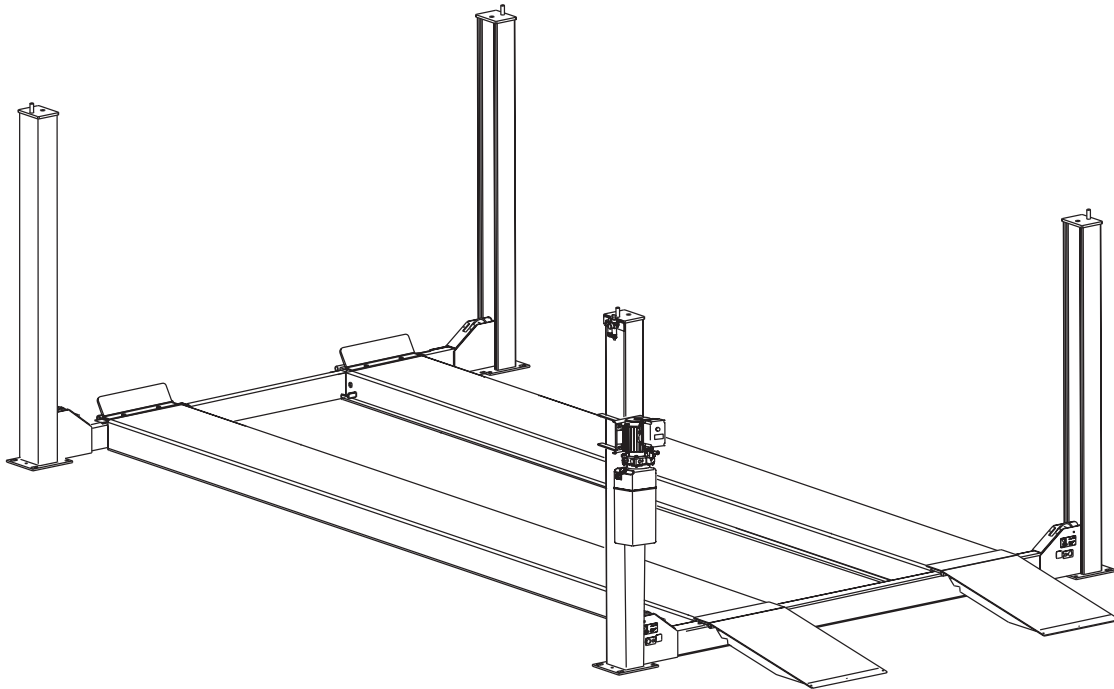

I
N
S
T
A
L
L
A
T
I
O
N
I
N
S
T
R
U
C
T
I
O
N
S

INSTALLATION INSTRUCTION

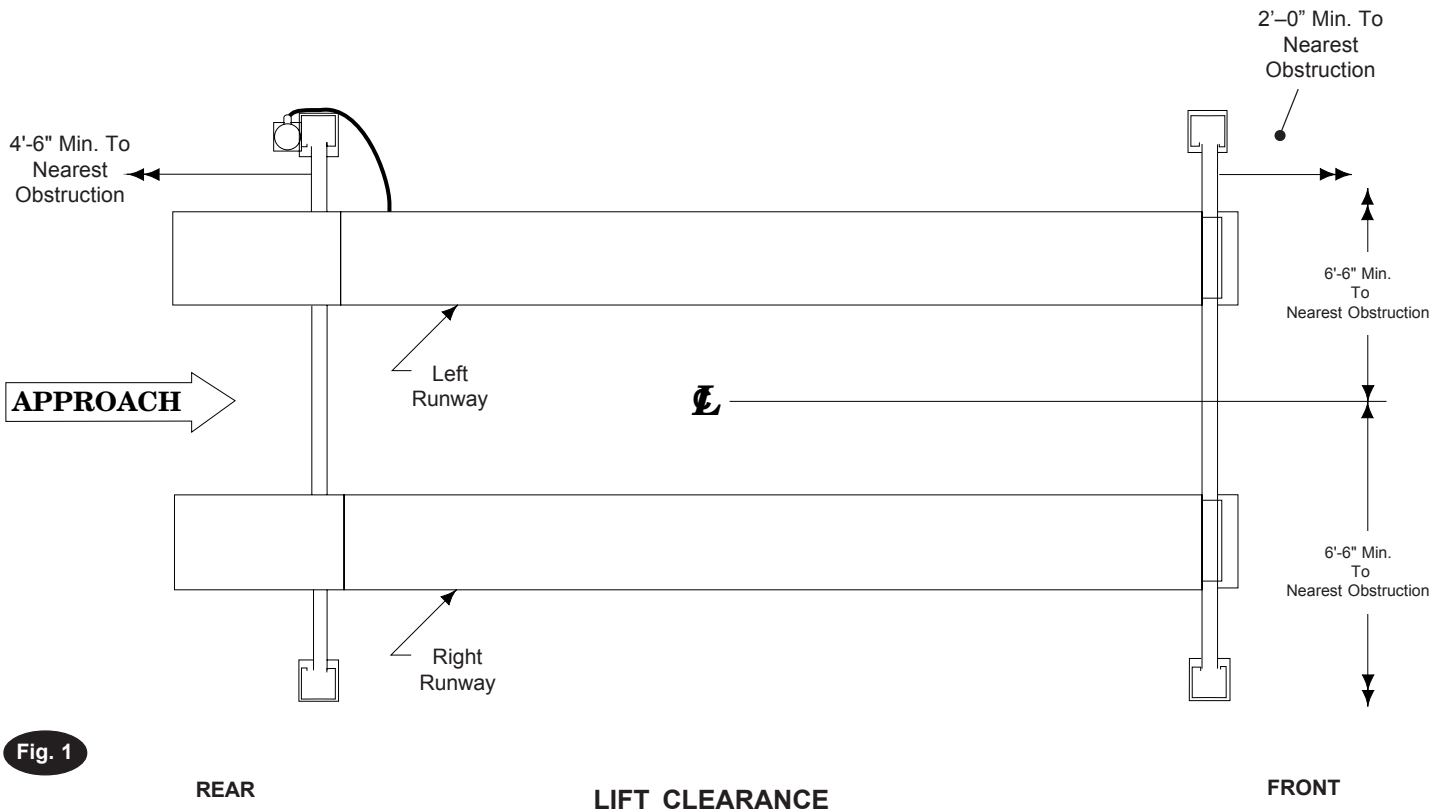

Fig. 1

Read and understand these instructions completely before proceeding with lift installation.

1. Lift Location: Use architects plan when available to locate lift. Fig. 1 shows dimensions of a typical bay layout. For power unit at right front, rotate lift 180°, leaving ramp/chocks and wheel stops in original position. Lift floor area should be level.

⚠ WARNING DO NOT install on asphalt or other similar unstable surface. Columns are supported only by anchors in floor of tallest vehicle.

2. Ceiling or overhead clearance must be 80" plus height of tallest vehicle.

3. Estimating Column Shim requirements:
In the following section, the terms "highest" and "lowest" refer to elevation of floor.

- Mark locations where lift columns will be positioned in bay.
- Place target on floor at column positions (**NOT** on column base plates) and record readings, Fig. 2.
- Find the highest of the four locations. Find the difference between the reading at each of the remaining three columns and the highest reading.
- The difference is the estimated amount of shim thickness needed at each column.

Note: Maximum shim thickness is 1/2" per column using shims and anchors provided with lift. Shim thickness of 2" is possible by using optional shim kit #FC5393.

Contact your authorized Rotary Parts Distributor for ordering information.

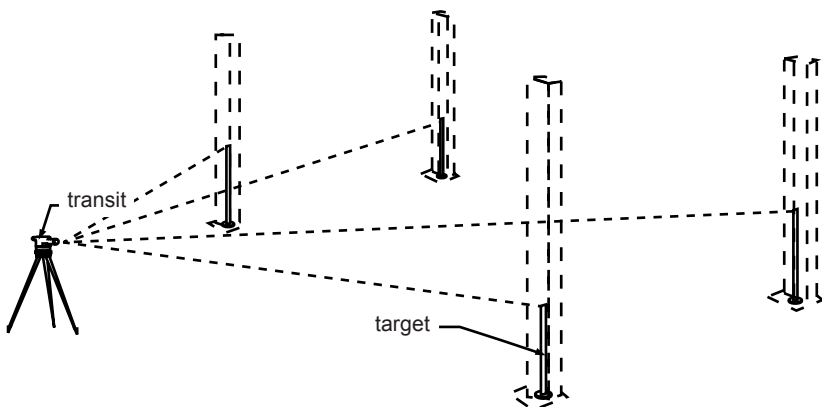

Note: Target is positioned on floor at planned column positions (**NOT** on column base plates).

Dimension at highest position minus other position
= shim thickness required

Fig. 2

COLUMN SHIM ESTIMATES

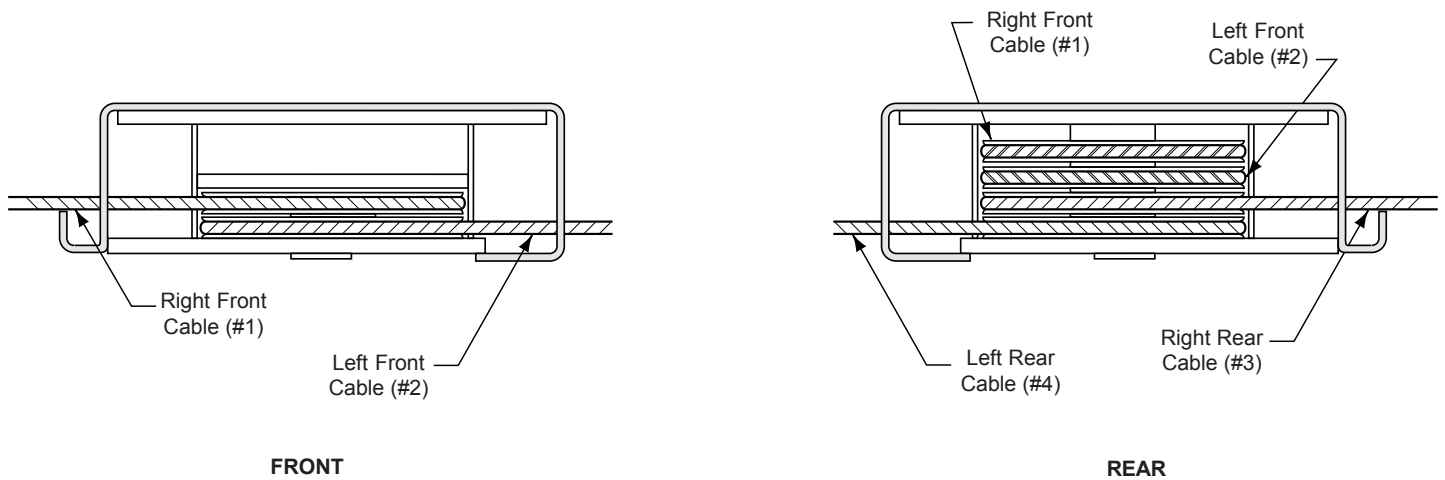

Fig. 3

CABLES IN PROPER SHEAVE GROOVES

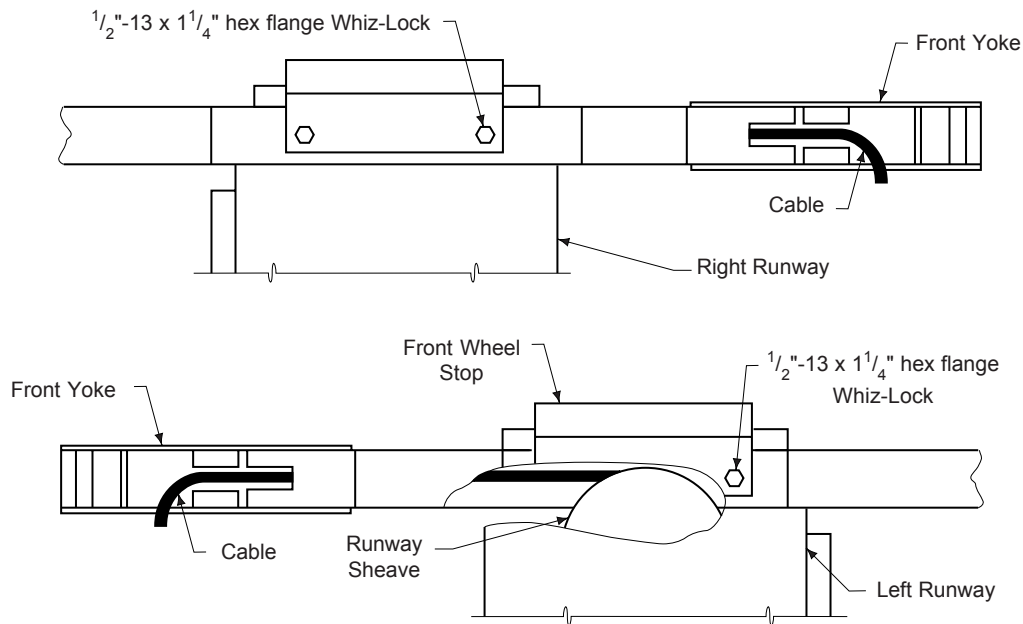

Fig. 4

FEED CABLE ENDS THROUGH YOKE OPENINGS

4. Runway and Yoke Tube Assembly:

- A. Determine direction of approach in bay.
- B. Position left runway in bay with hydraulic cylinder hose connection to rear of bay. Cables and sheaves are pre-assembled in runway. Runway needs to be up off floor so shipping restraints can be removed from cable ends, air and hydraulic lines, and cylinder rod. Pull cable ends, air, and hydraulic lines out for assembly. Make sure cables are in proper sheave grooves, Fig. 3.
- C. Position front and rear yokes at respective ends of runway, Fig. 1. The opening in the side of the yokes should be lined up with the cable sheaves in the runway ends. Feed cable ends through yoke openings, Fig. 4. Do not assemble sheaves in yoke ends at this time.

5. Runway and Wheel Stop Attachment:

With the openings in the yoke tube side lined up with the left runway ends, align the two (2) holes in the top of the front yoke tube with the slots in the runway end plates and the holes in the front wheel stops. Bolt runway to the yoke using four $\frac{1}{2}$ " x $1\frac{1}{4}$ " hex flange bolts, Fig. 4. The right runway may be located in two (2) locations on yokes, allowing for either 40" or 43" between runways. Align the slots of the right runway end plates with the desired set of holes in the yoke tube. Make sure front and rear are located in the same set of holes.

Note: If light kit or rolling jacks are to be used on lift, runways must be set at 43".

IMPORTANT Be sure cables are not crossed inside yoke.

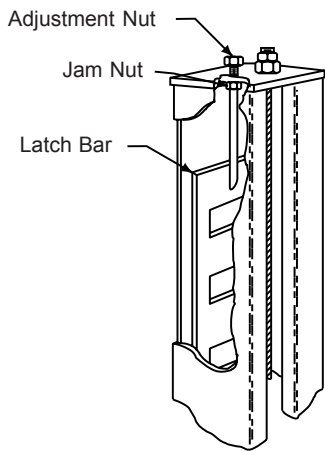

Fig. 5a

LATCH BAR IN COLUMN

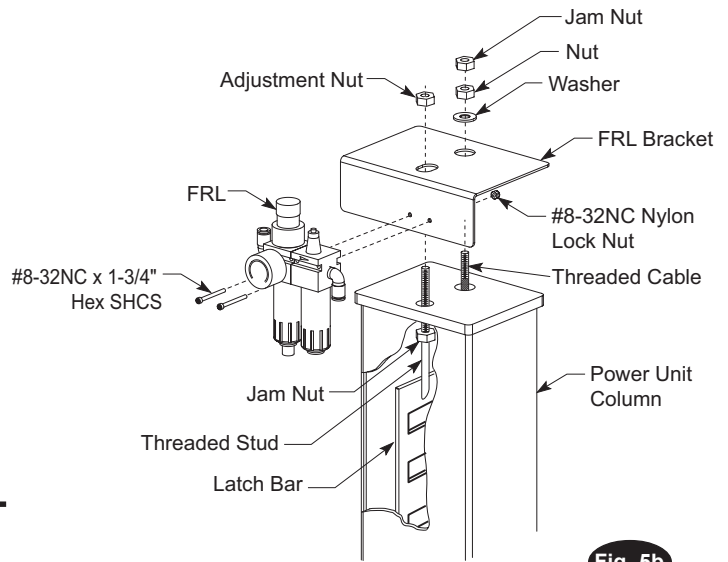

Fig. 5b

ATTACH FRL

6. Column and Yoke Assembly:

- A. Place the power unit column at the left rear corner of the lift. The hydraulic cylinder connection in the left runway should be visible from this corner. Position remaining three columns.
- B. Thread the jam nut down the threaded stud as far as possible. Stick rubber bumper to bottom of latchbar, see Fig. 7. Place the latch bar in the back of the column, Fig. 5a. The latch bar is offset from the center line of the threaded stud (inset Fig. 6). The latch bar should be oriented toward the back of the column from center line of the threaded stud.
- C. Place FRL Bracket on top of power unit column. Guide the threaded stud through the hole in the column top plate and bracket, Fig. 5b. Then thread the adjustment nut down the threaded stud until the nut and top plate are flush, Fig. 5b. Repeat for other columns.

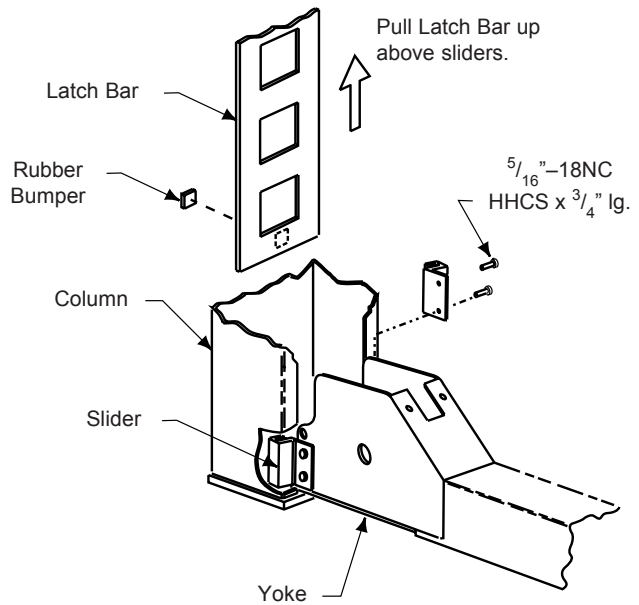

Fig. 7

ATTACH SLIDERS

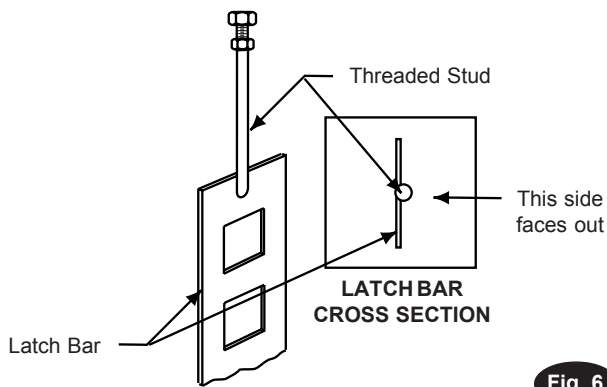

Fig. 6

LATCH BAR OFFSET

tighten. The latch bar should engage the sliders for at least 1" when the lift is completely lowered. Repeat this procedure for each yoke end and column.

- F. Install yoke end sheaves and plastic spacers, Fig. 8. A plastic spacer is placed on each side of the sheave, inset Fig. 8.

Note: Failure to install plastic spacer will result in premature failure and void warranty.

- G. Retain with sheave pin and 5/16" hex head machine bolt. Attach each cable to column top plate with spacer, nut, and jam nut, Fig. 8. Install rubber sheave guard on each yoke end, Fig. 8. Roping diagram shows a view of completed roping, Fig. 9.

IMPORTANT

Be sure cable is located in the sheave groove.

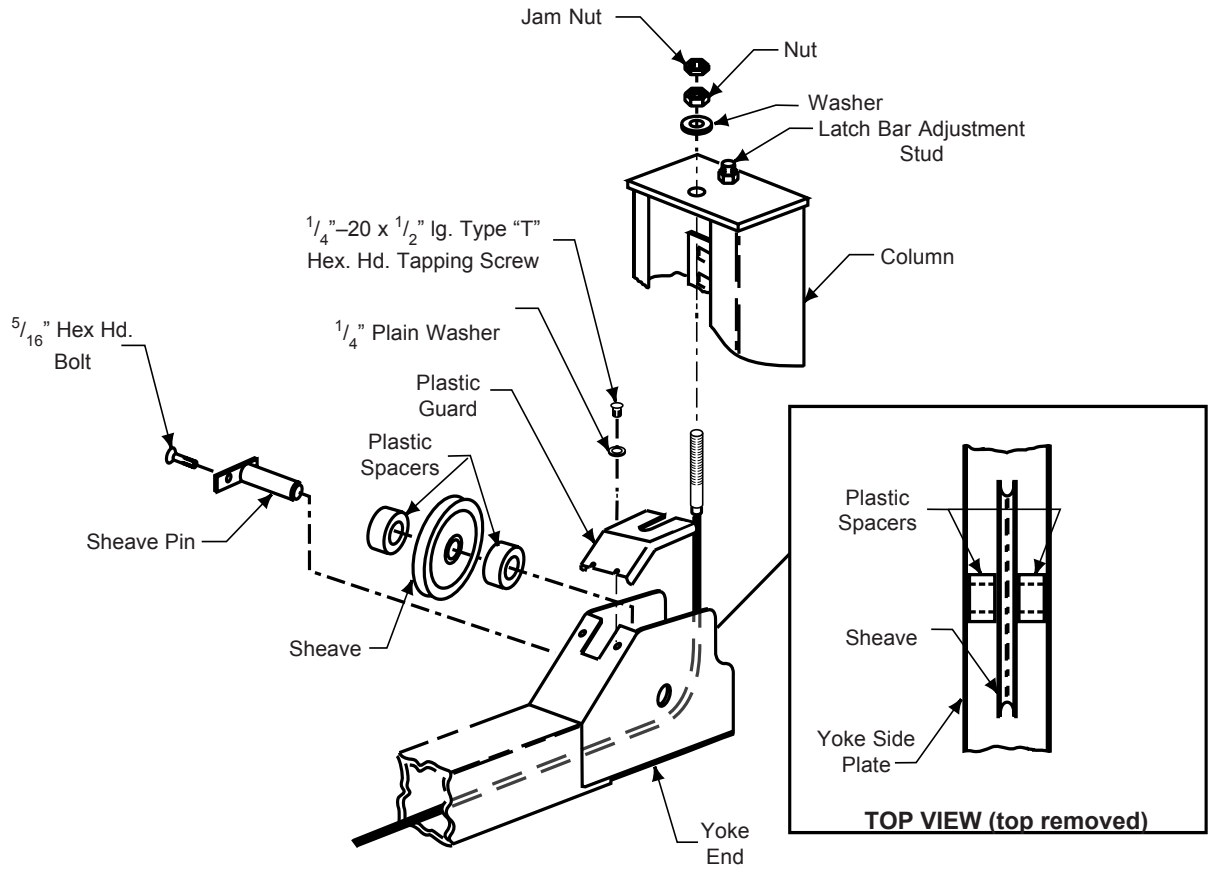

Fig. 8

SHEAVE INSTALLATION

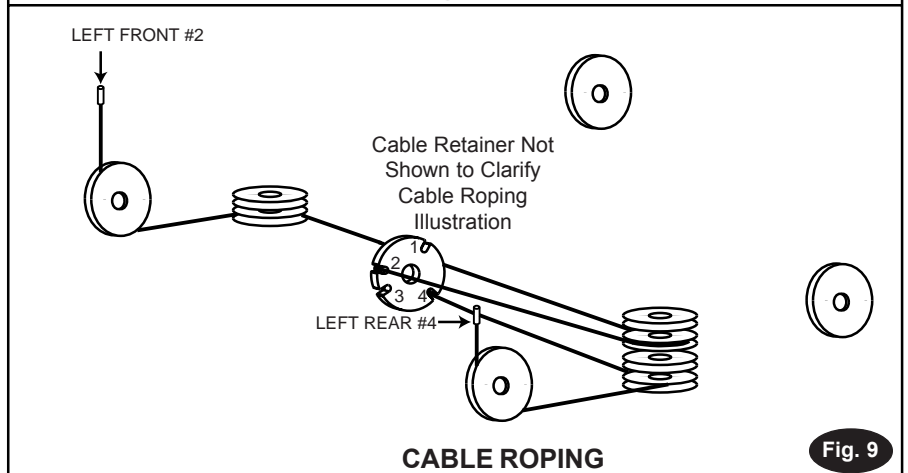
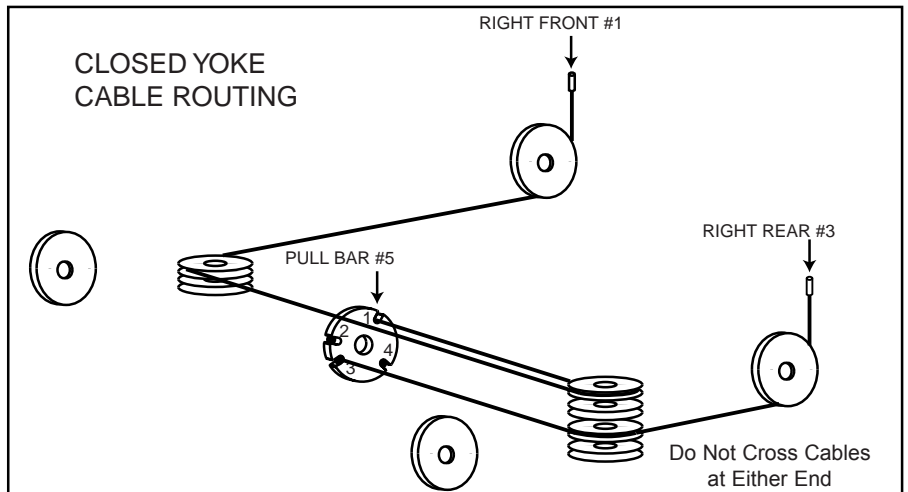
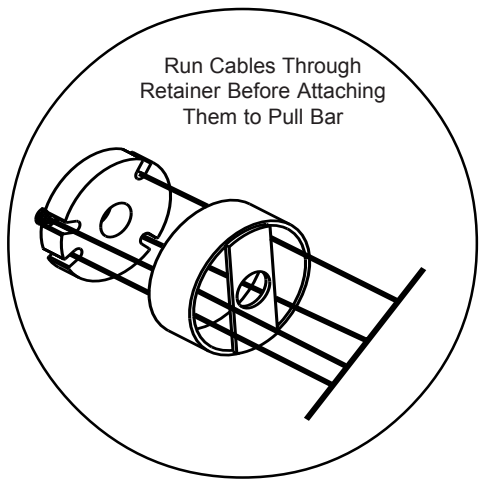

Fig. 9

7. Column Anchoring:

- A. Recommended floor thickness is 5" minimum and should sustain 2000# anchor load.
- B. Keep columns square to center line of lift. Check lift location in the bay. Check dimensions side-to-side, front-to-rear, and diagonally. Diagonals must be equal to within $\frac{1}{4}$ ", Fig. 11.
- C. Move column towards yoke until the sliders contact the back of column, center yoke in column, Fig. 10.

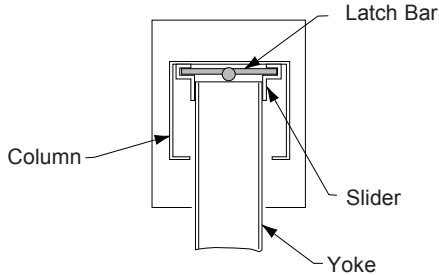
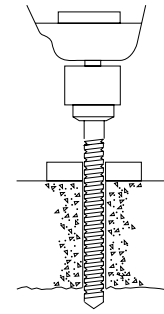
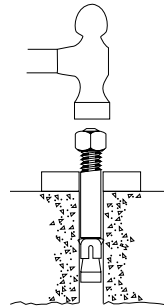

Fig. 10 COLUMN CROSS SECTION

- D. Place shims (estimated in Step 3) under each column. Drill four $\frac{5}{8}$ " diameter holes through concrete floor using base holes as guide, Fig. 12. Repeat for other columns.
- E. Insert base anchors, Fig.'s 12 and 13.
- F. Tighten nuts, Fig. 12. Check columns for plumb and level. Re-shim if necessary. Torque anchor bolts to 35-45 ft. lbs., Fig. 12.
- G. If anchor bolts do not hold when torqued to required amount, concrete must be replaced. Saw cut and remove 24" x 24" square area under each column base. Repour with reinforced 3000# minimum concrete to depth of 6", keying new concrete under existing floor.



Drill holes using $\frac{5}{8}$ " carbide tipped masonry drill bit per ANSI standard B94.12.1977



Remove washer. Run nut down, just below impact section of stud. Drive anchor into hole until nut contacts base.

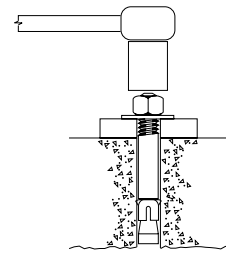

Replace washer. Tighten nut to 35-45 ft./lbs.

ANCHOR HOLES

Fig. 12

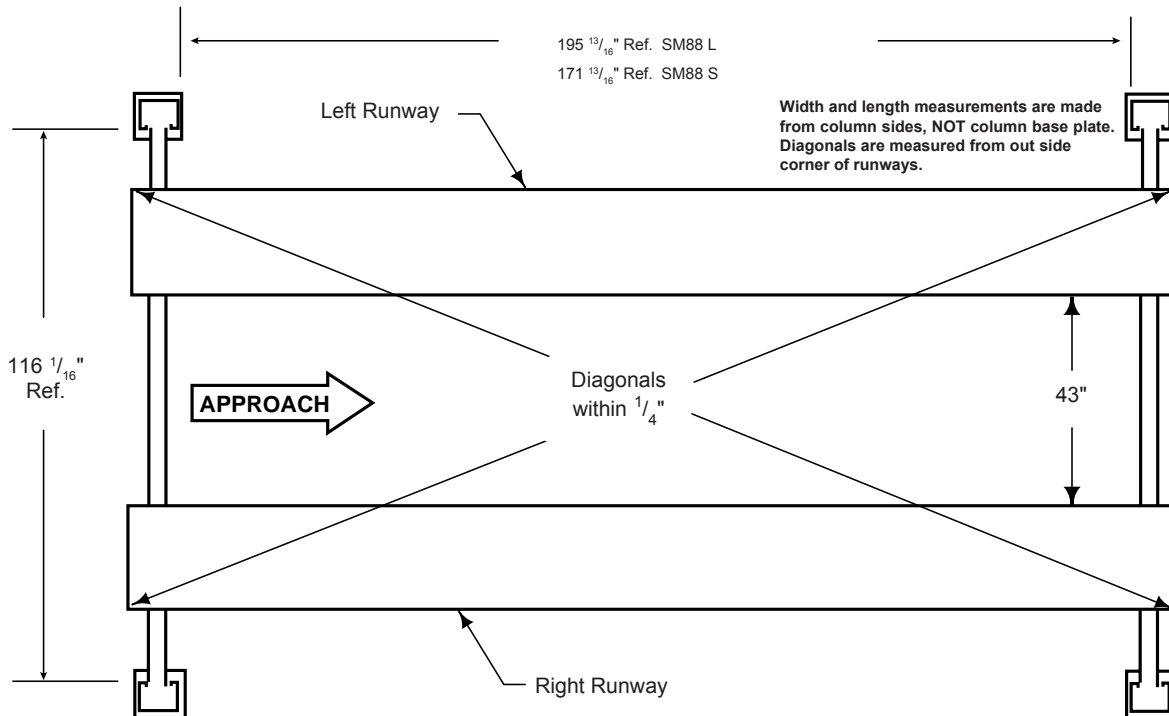

Fig. 11

CHECK DIAGONALS

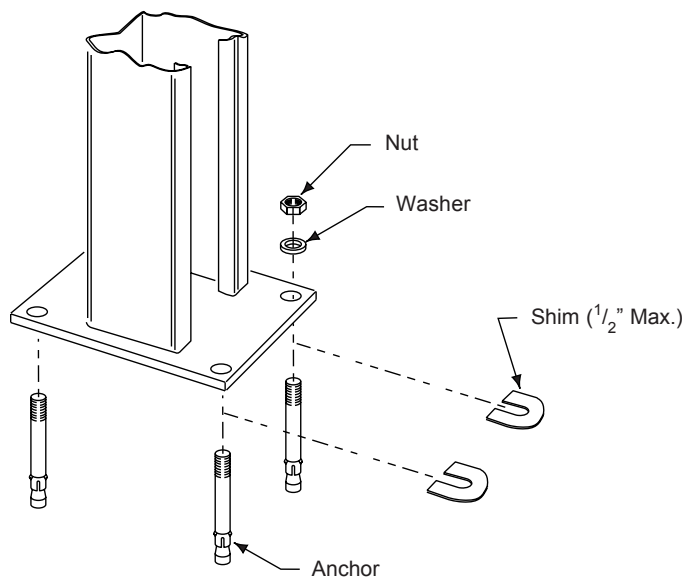

Fig. 13 INSERT ANCHORS

8. Runway Leveling:

- A. Use an engineer's automatic level (transit). Locate the Level at a convenient location in the shop that allows an unobstructed view of all four corners of the lift's runways. Follow the Level manufacturer's instructions for proper setup. Be sure it is adjusted level in all directions. Readjust Level if it or tripod is bumped or disturbed.
- B. Make sure yoke tubes rest on column base plate.

C. First place the Level target at the highest corner of the lift. Place it on the runway center line within 6" of yoke tube, whichever one is located over highest point. This will be referred to as target "A" position. Beginning with target "A" position, Fig. 14, sight the Level to the target and mark the number or the graduation on the inch scale of the target that aligns to the crosshairs of the Level, Fig. 15.

RUNWAYS SHOULD BE LEVEL MAXIMUM TOLERANCE
SIDE TO SIDE AND FRONT TO REAR $\frac{1}{8}$ "

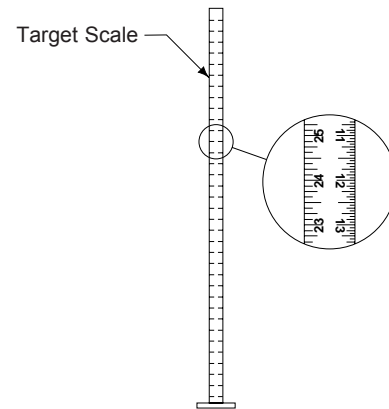

TARGET SCALE **Fig. 15**

Note: Use a pencil, marking pen or attach a paper clip on to the target scale at the crosshair reference.

- D. Next, move the target and place it on the runway at point "B", Fig. 14. Rotate the Level and focus on the target scale. Adjust the column at "B" using shims under base plate, Fig. 13, until the crosshairs of Level align to reference mark on the target scale. Repeat for points C and D.

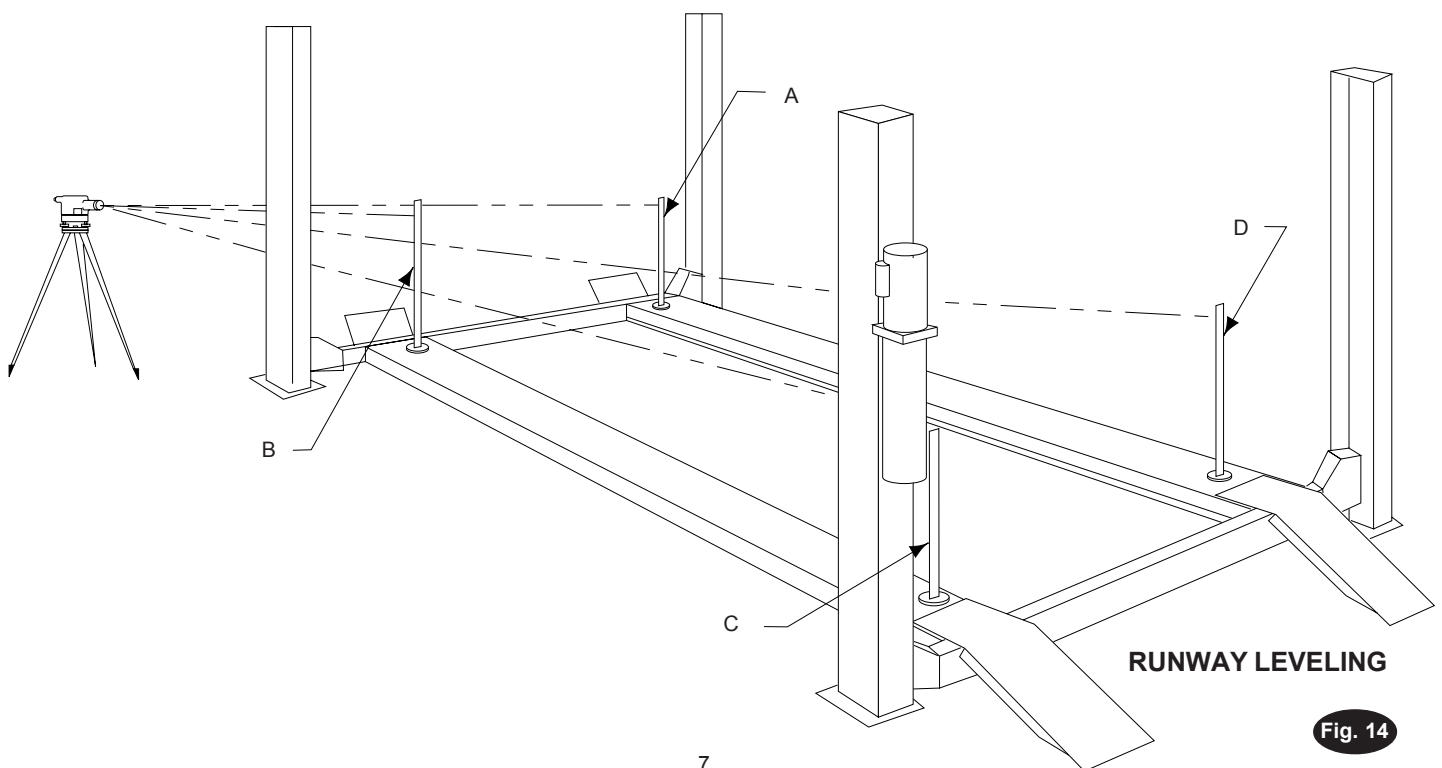

Fig. 14

9. Cable Adjustment:

Adjust cable with lift fully lowered. Loosen jam nut and tighten nut on cable stud on top of column until yoke end raises $\frac{1}{4}$ ". Back off nut one turn. Retighten jam nut. Repeat for all four cables. Refer to Fig. 8.

IMPORTANT Cables must fit in slack cable arm rollers, Fig. 16.

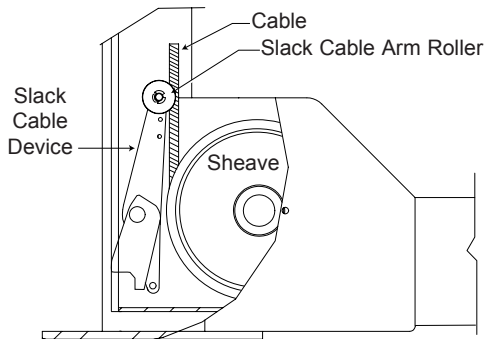

Fig. 16

CABLE IN SLACK CABLE ARM

10. Power Unit:

A. Align Air Valve Bracket with holes in right side of Column Bracket (with left side holes of Column Bracket if mounting on left). Insert four $\frac{5}{16}$ " x $1\frac{1}{2}$ " hex bolts through holes in Air Valve Bracket and Column Bracket. Use push nuts to hold in place. Fig. 17

B. Mount power unit, with motor up, to column bracket and install lock washers and nuts. Run hydraulic hose from runway through slot in side of runway to power unit output port. **DO NOT** use Teflon tape on hydraulic hose connections. Install and hand tighten elbow to pump until O-ring is seated and elbow should be oriented downward at approximately 45° , Fig. 18. Tighten locknut to 35-40 ft. lbs. Install enclosed Capacity label on power unit, Fig. 20.

C. Run hydraulic hose from runway through slot in side of runway, then to power unit output port. **DO NOT** use Teflon tape on hydraulic hose connections.

D. Install enclosed NP438 Capacity label on power unit, Fig. 18

11. **Electrical:** Have a certified electrician run 220 volt single phase 50 Hz. power supply to motor, Fig. 20. Size wire for 25 amp. circuit. See Motor Operating Data table below.

WARNING Risk of explosion. This equipment has internal arcing or sparking parts which should not be exposed to flammable vapors. It should not be located in a recessed area or below floor level.

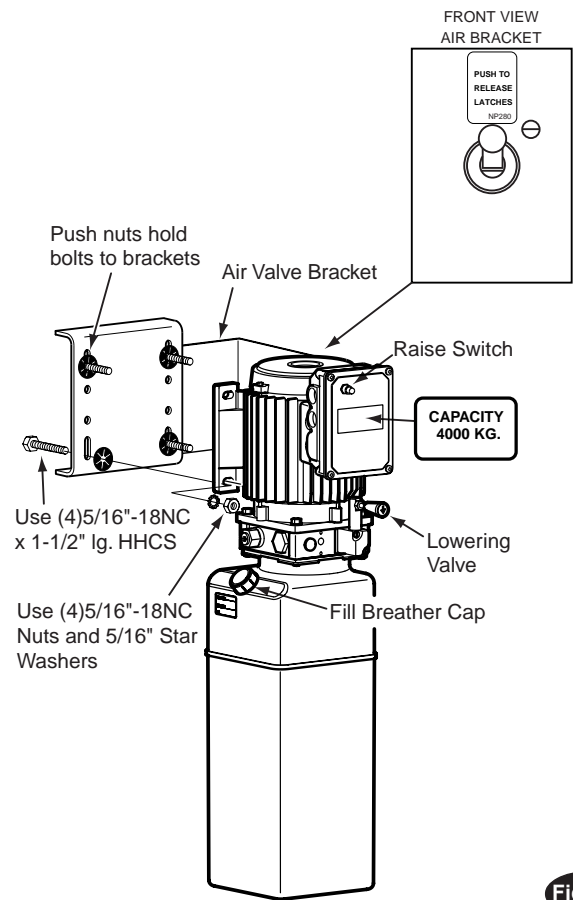

Fig. 17

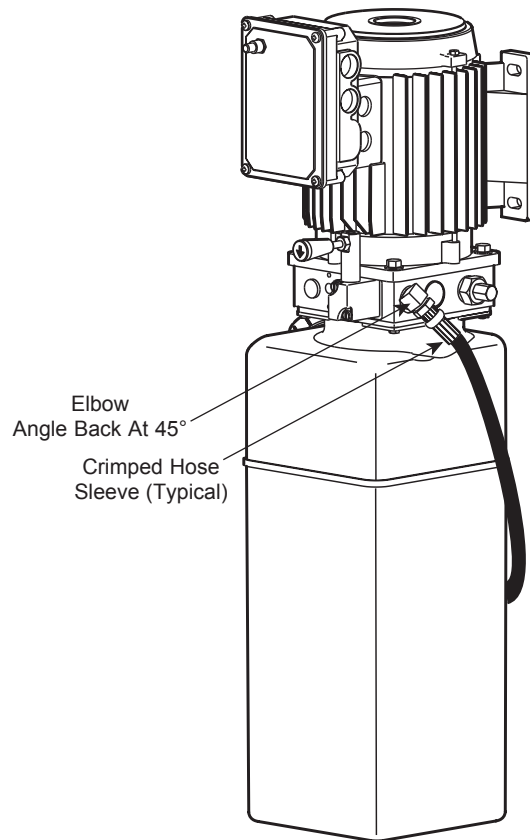

Fig. 18

Single Phase Power Unit

MOTOR OPERATING DATA TABLE - SINGLE PHASE	
LINE VOLTAGE	RUNNING MOTOR VOLTAGE RANGE
208-230V 50Hz.	197-253V

Note: 60Hz. Single phase motor CAN NOT be run on 50Hz. line without a physical change in the motor.

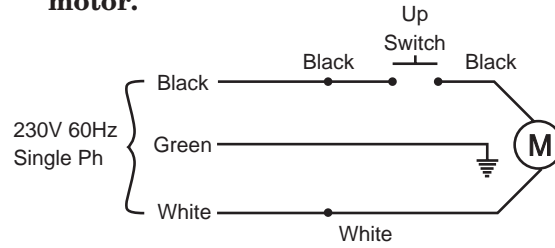

Fig. 20

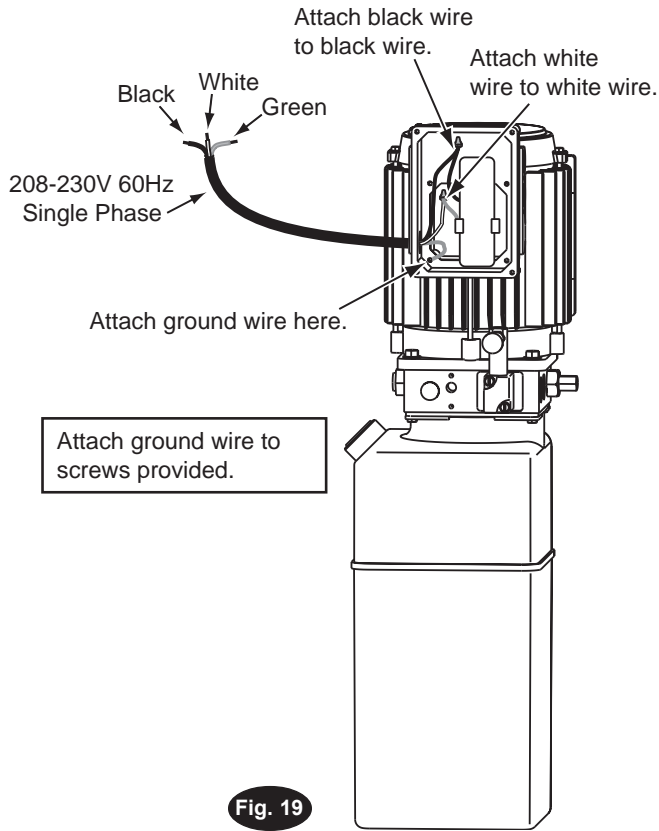
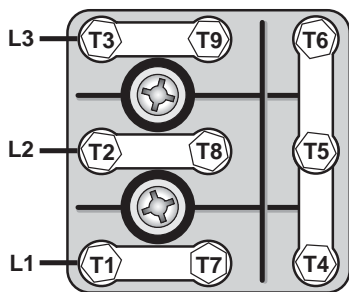
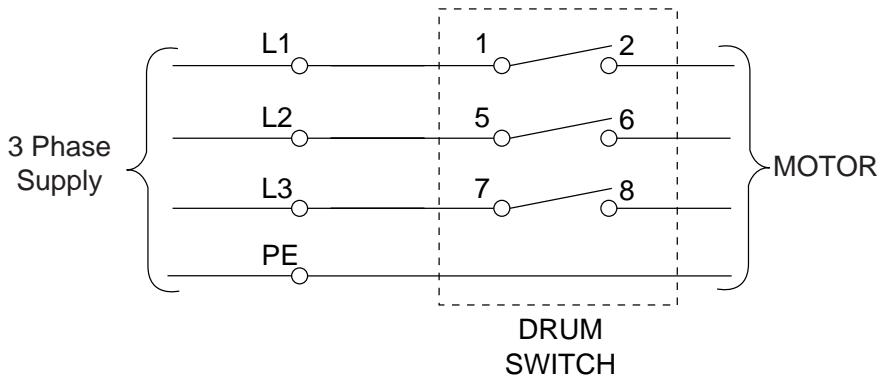
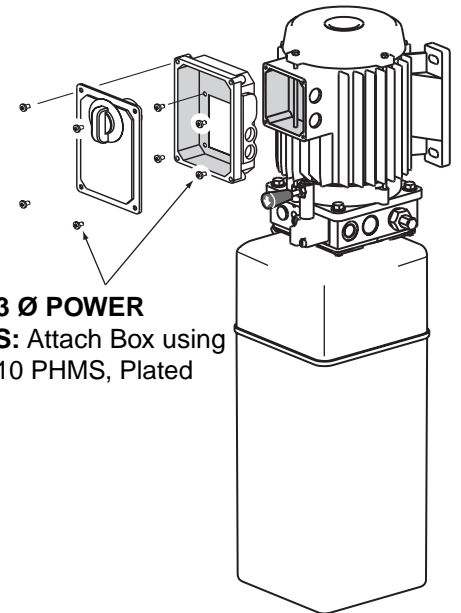

Fig. 19

MOTOR OPERATING DATA TABLE - THREE PHASE	
LINE VOLTAGE	RUNNING MOTOR VOLTAGE RANGE
380V 50Hz.	380-415V

NOTES:

- Unit not suitable for use in unusual conditions. Contact Rotary for moisture and dust environment duty unit.
- Control Box must be field mounted to power unit.
- Motor rotation is counter clockwise from top of motor.



208-240V
50/60Hz. 3Ø

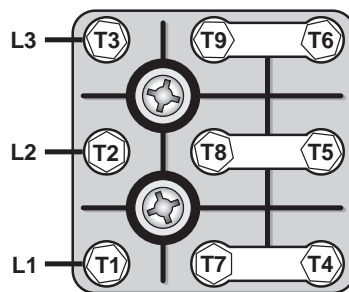

440-480V 50/60 Hz. 3Ø
400V 50 Hz. 3Ø

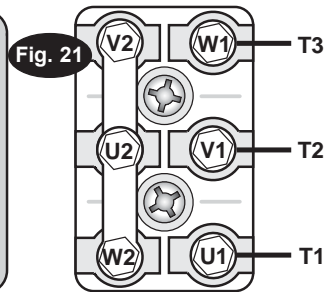

575V 60 Hz. 3Ø

Fig. 21

CAUTION Never operate the motor on line voltage less than 208V. Motor damage may occur.

IMPORTANT Use separate circuit for each power unit. Protect each circuit with time delay fuse or circuit breaker: For single phase 208-230V, use 25 amp. fuse, and three phase use 15 amp. fuse. For three phase wiring see Fig. 21. Wiring must comply with local electrical codes.

12. Hydraulic Fluid Filling: System capacity is thirteen (13) quarts. Use Dexron III ATF or equal. Fully lower lift. Remove fill/breather cap and vent screw, Fig. 19. Fill to vent hole. Replace fill/breather cap.

Note: If fill/breather, Fig. 18, is lost or broken, order replacement.

13. Air Line Connections:

Note: Locking latches require 100 psi. min. to 120 psi. max. air pressure.

A filter/regulator/lubricator must be installed on air supply at lift. Failure to do so will void the warranty.

- A. Lift should be at full height and lowered on latches.
- B. Connect air valve to Reducing Tee, Fig. 22. Cut provided $\frac{1}{4}$ " air line tubing with sharp blade to length as required. Tubing must be cut square with no burrs.

Note: To assemble air line tubing into fitting, use firm, manual pressure to push tubing into fitting until it bottoms, Fig. 23. If removal of the air line tubing from the fitting is ever required, hold Push Sleeve in (against fitting) and, at the same time, pull out on tubing.

- C. Attach air valve to air bracket see, Fig. 22.
- D. Attach enclosed NP280 decal ("PUSH TO RELEASE LATCHES") above button on air valve bracket, Fig. 23. Run $\frac{1}{4}$ " air line from air valve to the slot in the fixed runway. Cut airline and attach a Tee, Fig. 26.
- E. Run $\frac{1}{4}$ " air line from the Tee of the runway slot through the guide tubes on the inside wall of the runway to the Tee in the front yoke, Fig. 25.
- F. Run $\frac{1}{4}$ " air line from the Tee at the runway slot to the Tee in the rear yoke.
- G. Run $\frac{3}{8}$ " air line from existing facility main air supply to the FRL. Run $\frac{3}{8}$ " air line from FRL to reducing tee, Fig. 22.
- H. Check for air leaks by depressing air valve. Repair as required.
- I. Use provided cable ties to tie air line to hydraulic hose between power unit and lift.
- J. Actuate air valve and check latch operation on

all four corners. The locking latches should pull in beyond yoke ends to clear the latch bars located in all four columns, Fig. 24.

- K. Use cable ties provided to tie $\frac{3}{8}$ " air supply to electrical supply conduit at approximately 2'-0" intervals.

14. Bleeding: Lift must be fully lowered before changing or adding fluid. Raise and lower lift six times. The cylinder is self-bleeding. After bleeding system, fluid level in power unit reservoir may be down. Add more ATF, if necessary, following instructions in Step 12.

To pressure test, run lift to full rise and run motor for approximately 5 seconds. Stop and check all fittings and hose connections. Tighten or reseal if required. Lower lift.

Note: Some test fluid may be spilled from the cylinder breather vent during bleeding of the system.

15. Assemble ramp/chocks to rear of runways using hinge pins and cotter pins, Fig. 26.

16. Final Adjustments:

- A. Load vehicle such as an RV onto lift.
- B. Raise lift to full height. You will hear the locking latch click through all 12 latch slots.
- C. Lower lift onto topmost latch position.
- D. Check latch clearance.
 1. Starting with the right front column: use a straight edge to mark the yoke height on the column, Fig. 27.
 2. Raise lift to full height again. Mark second position. If gap between two marks is less than 2", adjust locking latch bar to reach clearance of 2".
 - a. Adjust locking latch bar adjusting nut so that the bottom of the topmost latch bar slot is at least 2" below locking latch, Fig. 28. After adjustment, tighten jam nut underneath column top plate, Fig. 28.
 - b. If entire 2" clearance cannot be attained by adjusting the locking latch bar, adjust the cable stud. Loosen cable jam nut, Fig. 28, and turn adjusting nut to raise the locking latch 2" above bottom of latch bar slot. Tighten cable jam nut.
 3. Lower lift and remove vehicle.
- E. Raise the lift to full height. Listen **and watch** as the locking latches click in place. Synchronize the other three columns with the right front column by adjusting their cables so all four latches click at same time. Tighten jam nuts.

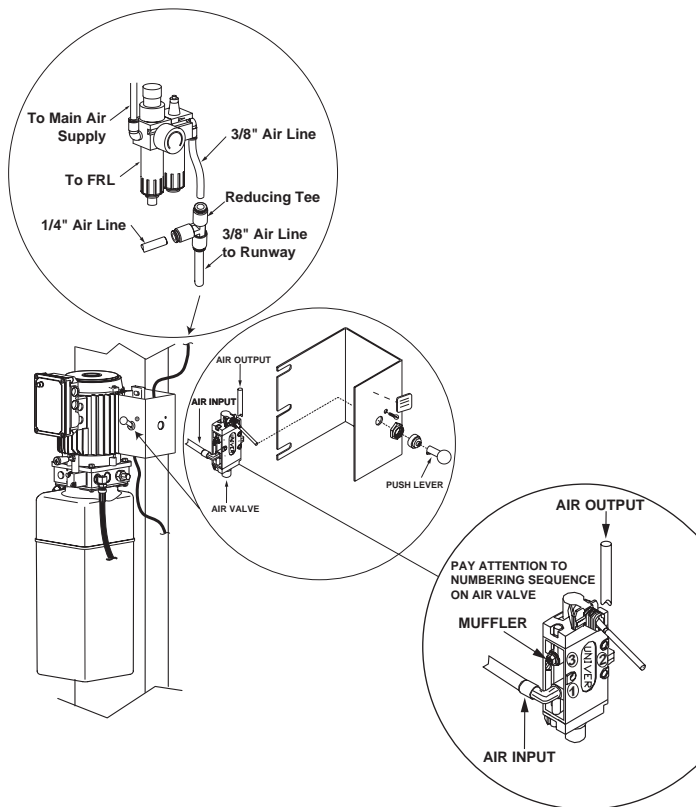
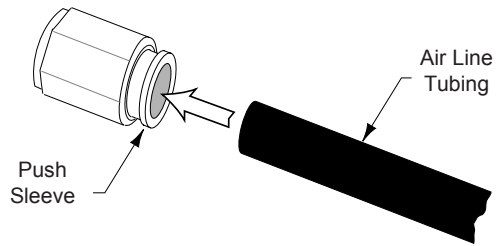
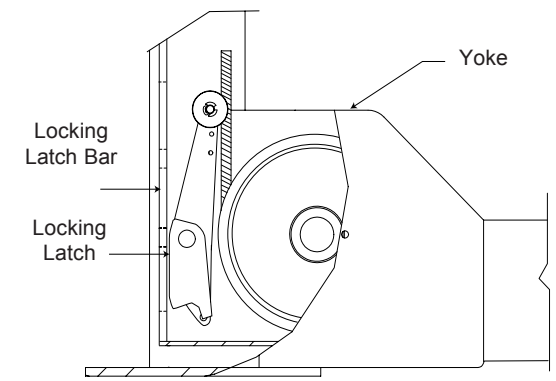

Fig. 22



AIR LINE INTO FITTING

Fig. 23



LATCHES SHOULD CLEAR LATCH BARS

Fig. 24

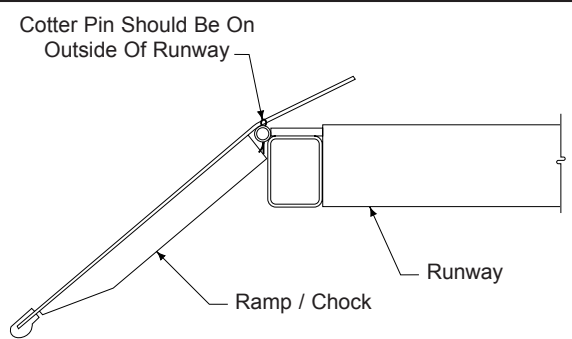
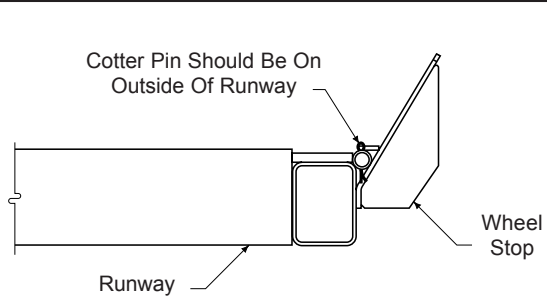

WHEEL STOP / RAMP CHOCK ATTACHMENT

Fig. 26

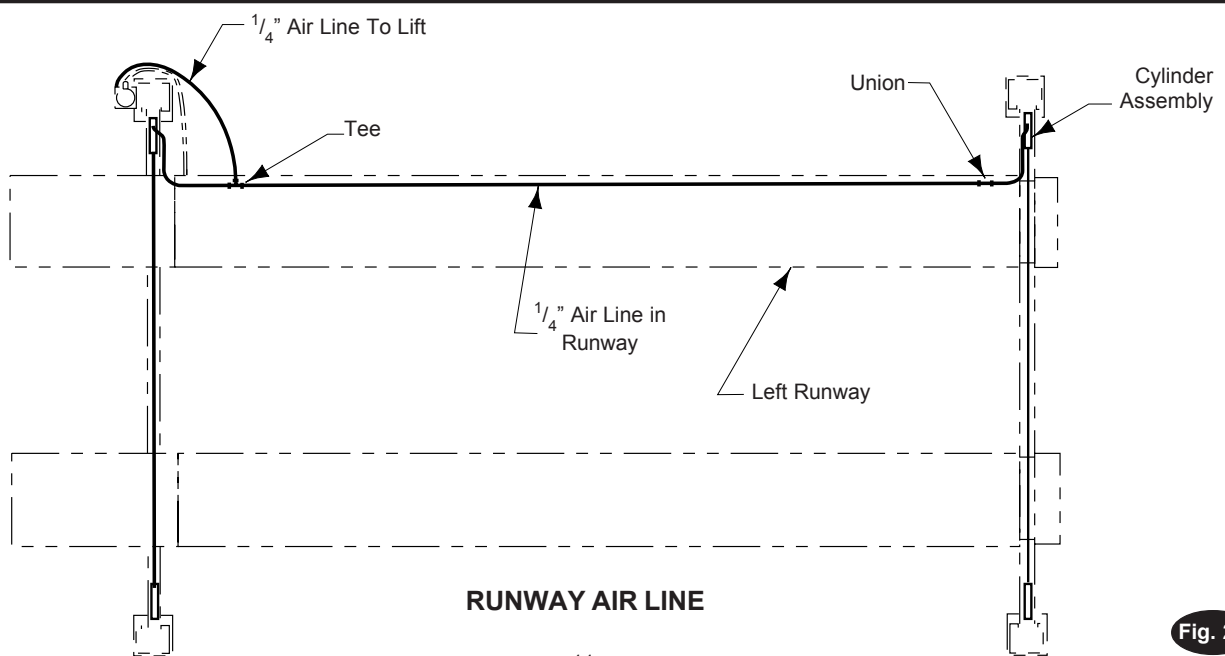

Fig. 25

⚠ WARNING When making changes to adjustment nuts on cable end or latch bar stud always leave at least two threads showing between nut and end.

Note: Latches may not click in at the same time when vehicle is being raised. They should be close. Be sure all four corners have passed the locking latch bar slot before lowering lift on locking latches.

Note: All bolts and nuts mentioned in this booklet are grade 5 unless otherwise stated.

IMPORTANT Cotter pins are usually good for onetime use only. Replace any cotter pin, if removed, with a new cotter pin.

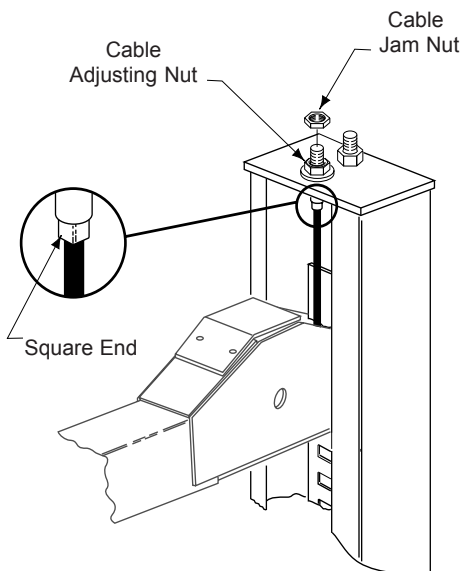
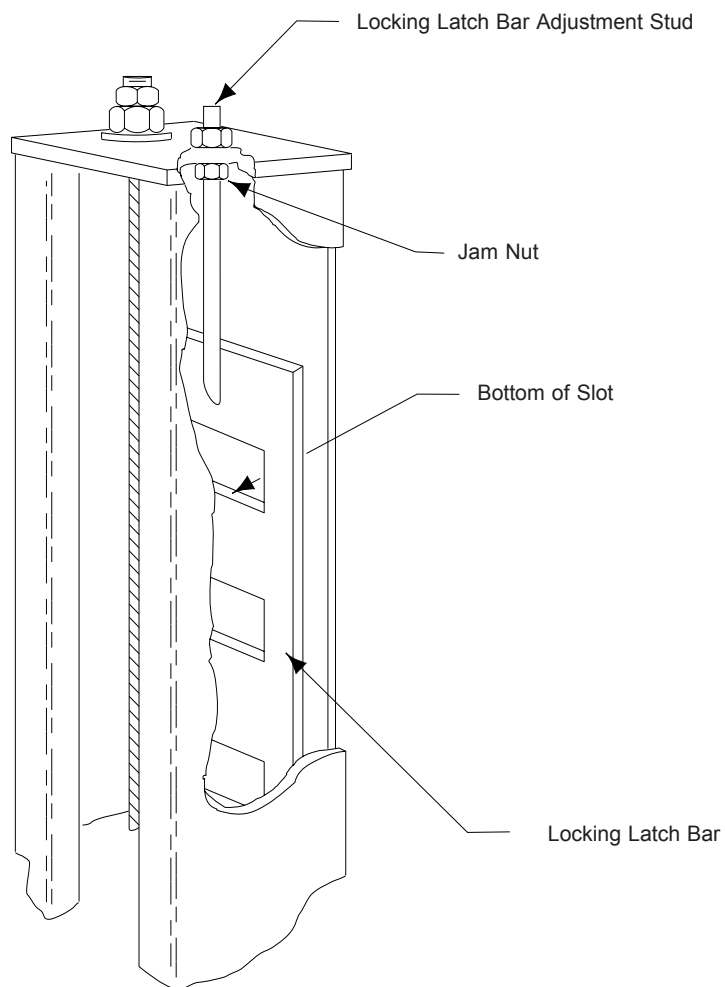

Fig. 27



**ADJUST LOCKING LATCH BAR
ADJUSTMENT NUT**

Fig. 28

1. Rolling Jack:

- A. Adjust rolling jack telescopic ends until roller rests on runway track rail. Make sure wheels are on tracks and center rolling jack between runway on end sections.
- B. Place jack on runway track at front and rear with air pump facing ends of runway, Fig. 29.
- C. Recommended operating pressure 100-120 psi.
- D. Attach rubber stop see Fig. 29.

2. Internal Air Line: (if installed)

This lift is equipped with an internal airline that provides air to both rolling jacks and extra access point for air driven tools (Quick Disconnect Coupler), Fig. 30. All internal air lines are factory assembled.

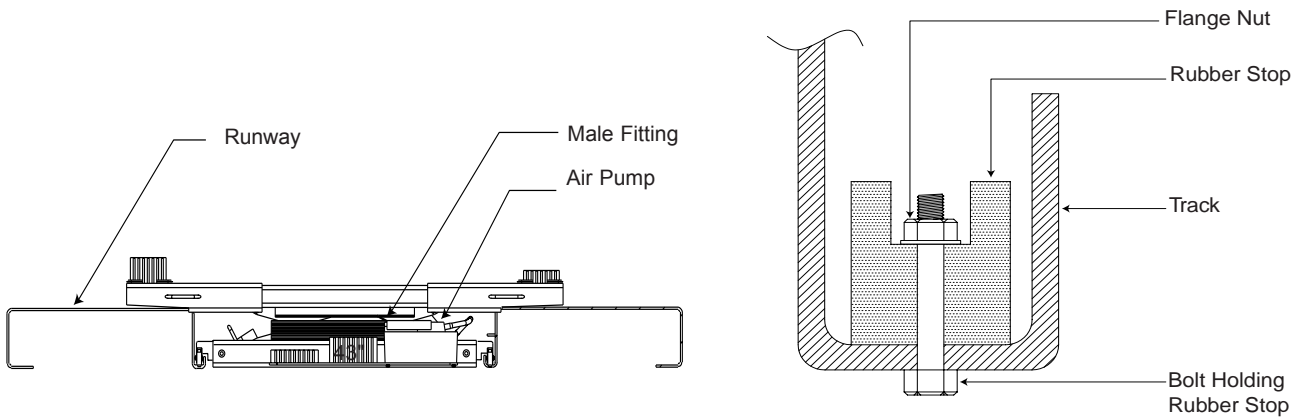

Fig. 29

Attach rubber bridge stops to 5/16" holes 14" off center of runways. Insert 1/4" bolt up through runway and stop. Attach 1/4" flange nut to top of stop.

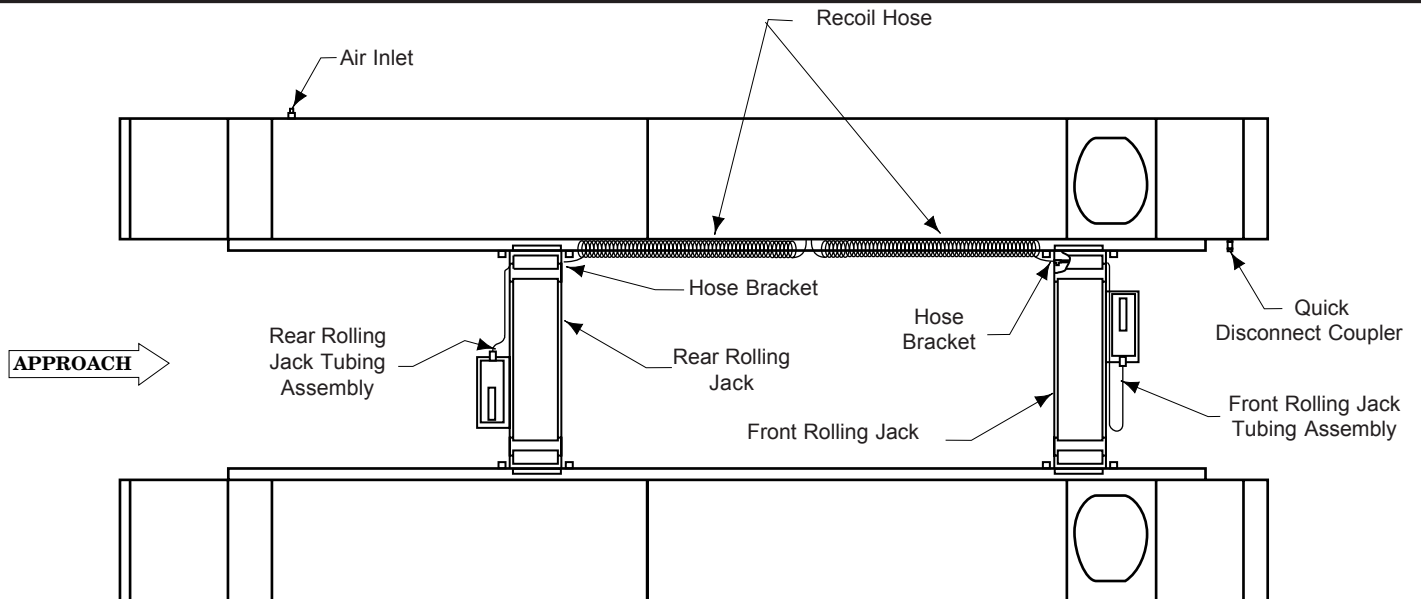

Fig. 30

3. Rear Recoil Hose Installation:

- A. Attach retainer brackets for the rear recoil hose with 3/8"-16NC x 3/4" Lg. hex cap screw, flat washer, lock washer and nut, Fig. 31.
- B. Insert retainer cable through coils of recoil hose, Fig. 35. Run a 1/4"-20NC hex nut down onto each end of retainer cable. Insert each end of cable into retainer brackets. Secure each cable end with another 1/4"-20NC hex nut. Tighten jam nuts, Fig. 31.
- C. Connect one end of provided rear recoil hose to bulkhead T-fitting at midpoint of runway. Connect other end of recoil hose to coupling welded on rolling jack, Fig. 32 and 34.
- D. Connect elbow end of rolling jack tubing assembly to air pump and male end to the coupling, Fig. 32 and 34.

4. Front Recoil Hose Installation:

- A. Insert retainer cable through coils of recoil hose, Fig. 31. Connect one end of recoil hose to coupling welded on rolling jack, Fig. 34 and 35.
- B. Connect other end of front recoil hose to bulkhead T-fitting in center of runway.
- C. Connect elbow end of rolling jack tubing assembly to air pump, and male end to the coupling, Fig. 34 and 35.

Note: Cut air line tubing with sharp blade to length as required. Tubing must be cut square with no burrs. To assemble air line tubing into fitting, use firm, manual pressure to push tubing into fitting until it bottoms, (see below). If removal of the air line tubing from the fitting is ever required, hold Push Sleeve in (against fitting) and, at the same time, pull out on tubing.

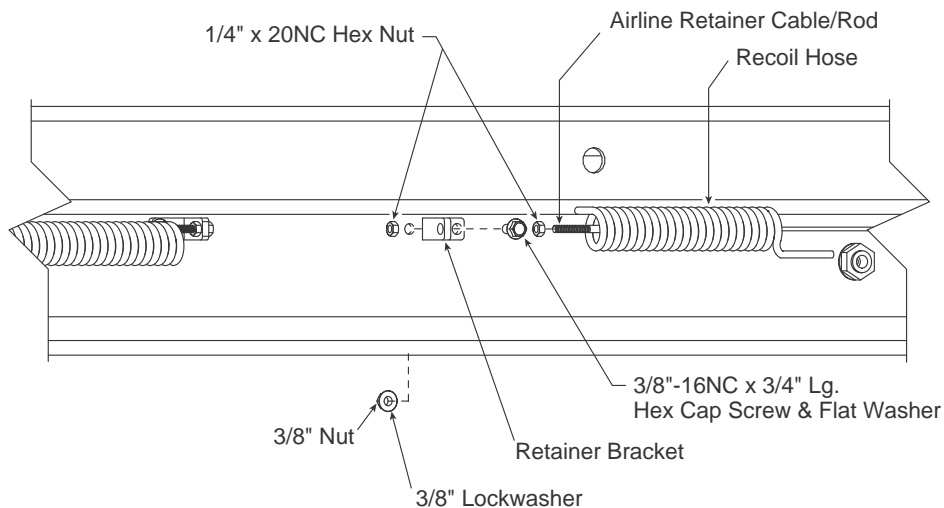

Fig. 31

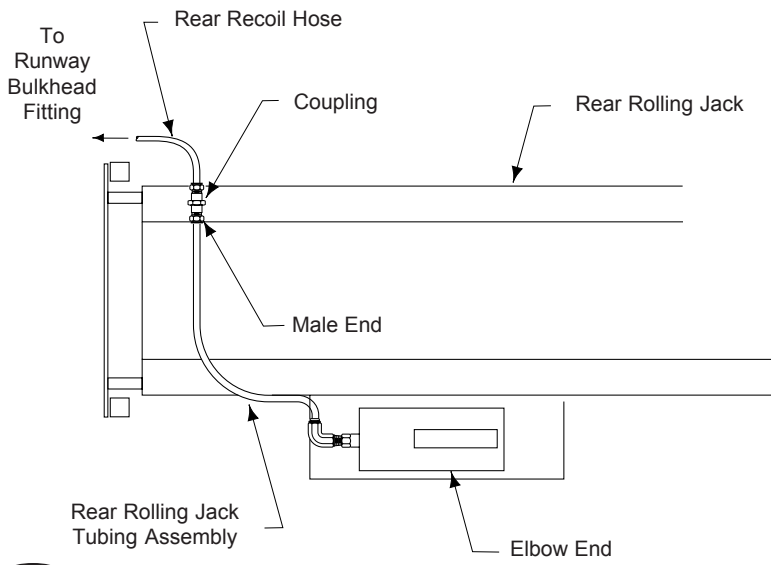

Fig. 32 REAR ROLLING JACK TO RECOIL AIR HOSE

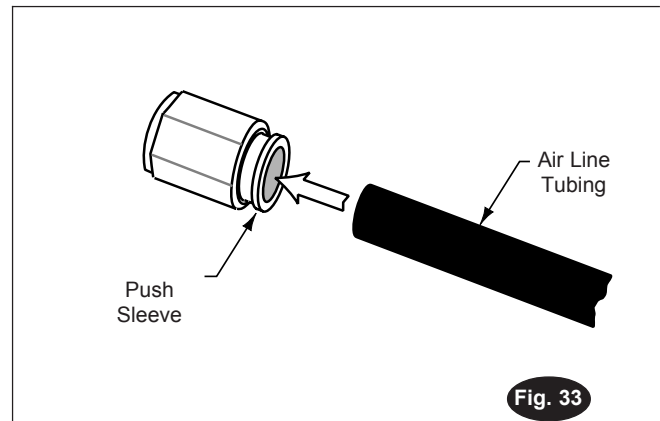
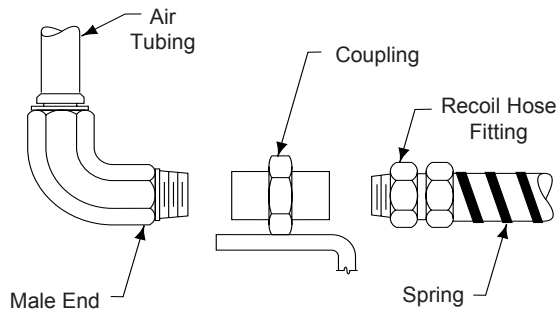
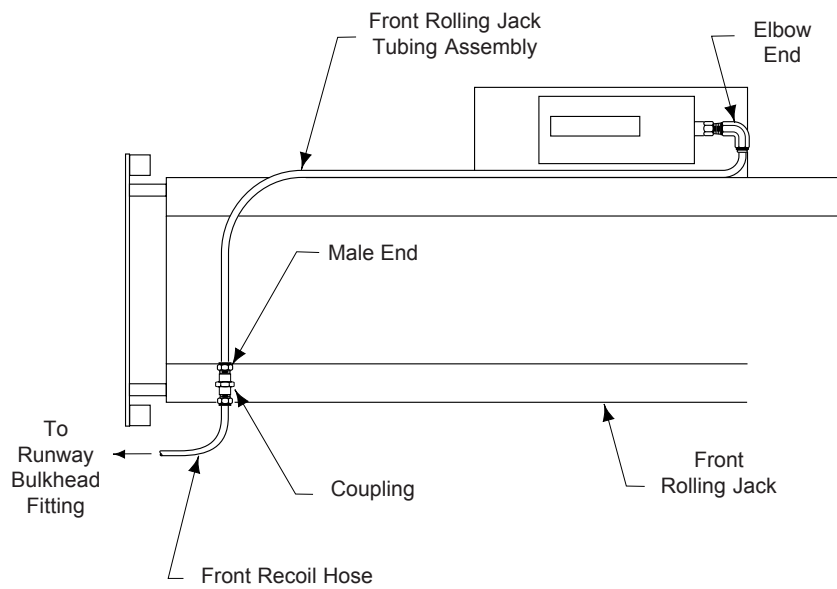

Fig. 33



COUPLING ON ROLLING JACK Fig. 34



FRONT ROLLING JACK TO RECOIL AIR HOSE Fig. 35

Installer: Please return this booklet to literature package, and give to lift owner/operator.

Thank You

Trained Operators and Regular Maintenance Ensures Satisfactory Performance of Your Rotary Lift.

Contact Your Nearest Authorized Rotary Parts Distributor for Genuine Rotary Replacement Parts. See Literature Package for Parts Breakdown.

Rotary World Headquarters

2700 Lanier Drive
Madison, IN 47250, USA
www.rotarylif.com

North America Contact Information

Tech. Support: p 800.445.5438
f 800.578.5438
e userlink@rotarylif.com
Sales: p 800.640.5438
f 800.578.5438
e userlink@rotarylif.com

World Wide Contact Information

World Headquarters/USA: 1.812.273.1622
Canada: 1.905.812.9920
European Headquarters/Germany: +49.771.9233.0
United Kingdom: +44.178.747.7711
Australasia: +60.3.7660.0285
Latin America / Caribbean: +54.3488.431.608
Middle East / Africa: 1.812.273.1622



A **DOVER** COMPANY

