

Installation Instructions

DS7000I

Recess Mounted Version

Capacity 7000 lbs. (3175 Kg)

Maximum 3500 lbs. (1587 Kg) per pad

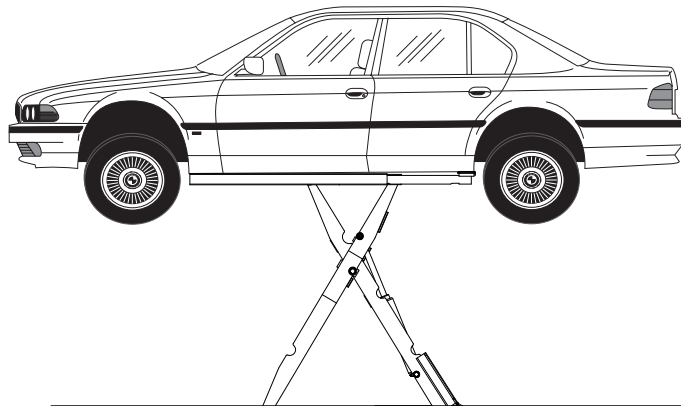

DS7000N

Surface Mounted Version

Capacity 7000 lbs. (3175 Kg)

Maximum 3500 lbs. (1587 Kg) per pad

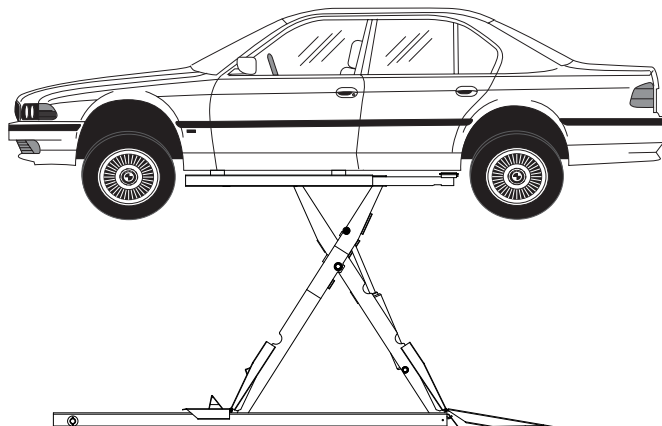

LP50031

OVERALL DIMENSIONS DS700N (SURFACE VERSION)

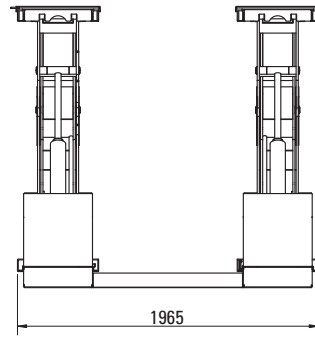
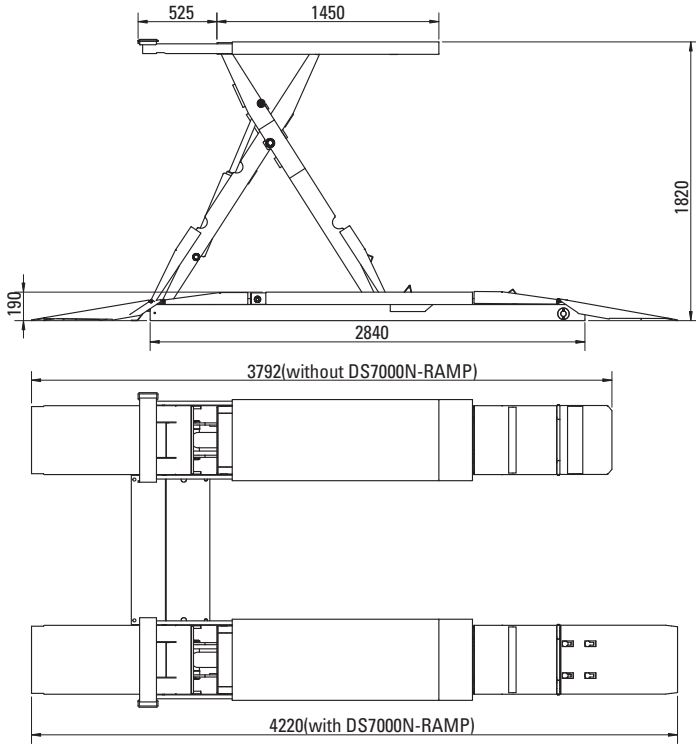

Model	DS700N Surface mounted
Lifting Capacity	3175kg (7000 lbs.)
Lifting Height (without rubber pad)	1820mm (71-5/8")
Minimum Height	189mm (7-3/8")
Overall Width	1965mm (77-3/8")
Overall Length	3730mm (146-7/8")
Width of Platforms	530mm (20-3/4")
Length of Platforms	1450mm (57")
Width Between Platforms	905mm (35-5/8")
Pulling Length of Arms	525mm (20-5/8")
Motor Power	1.5kw - 3kw (2-3hp)
Power Option	1Ph/220v/60Hz/208-230 1Ph/50Hz/230 3Ph/50Hz - 60Hz/208-480

OVERALL DIMENSIONS DS700I (RECESS VERSION)

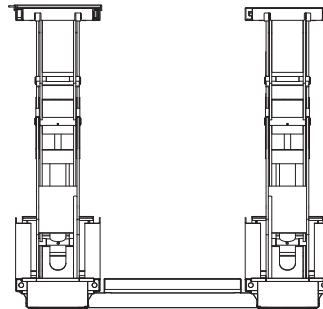
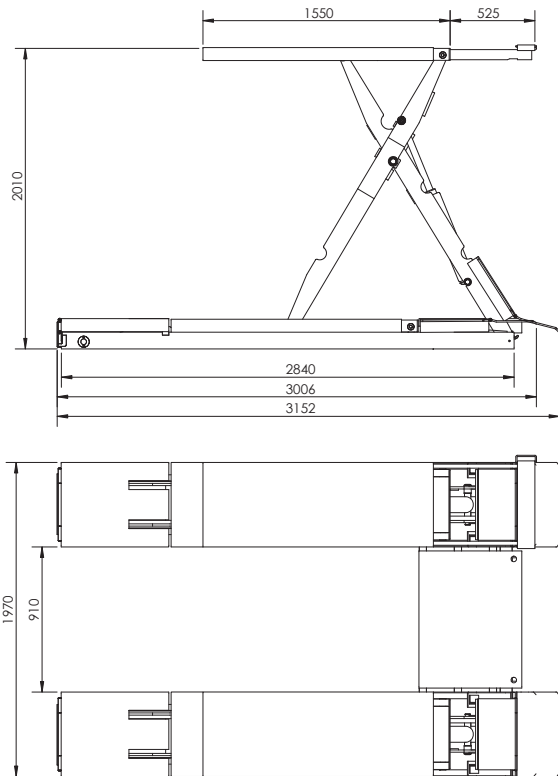

Model	DS7000I Flush mounted
Lifting Capacity	3175kg (7000 lbs.)
Lifting Height (without rubber pad)	2010mm (79-1/8")
Minimum Height	189mm (7-3/8")
Overall Width	1970mm (77-1/2")
Overall Length	2997mm (117-7/8")
Width of Platforms	530mm (20-3/4")
Length of Platforms	1550mm (61")
Width Between Platforms	910mm (35-3/4")
Pulling Length of Arms	525mm (20-5/8")
Motor Power	1.5kw - 3kw (2-3hp)
Power Option	1Ph/220v/60Hz/208-230 1Ph/50Hz/230 3Ph/50Hz - 60Hz/208-480

DS700I RECESS DETAIL

Floor reinforcement required
For floor reinforcing see
Architectural drawings and see note 2

51mm x 51mm x 6mm Angle (Edging)
Typical All Around Perimeter Of Trench

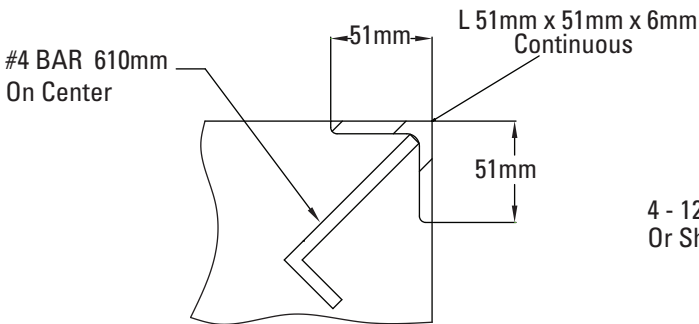
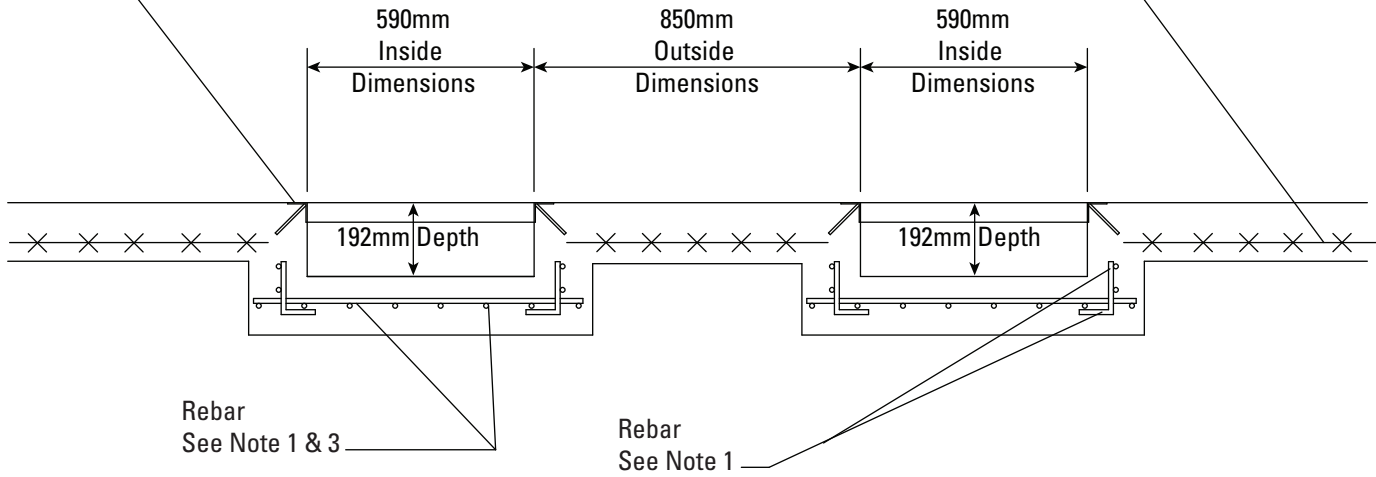

Trench Edging Detail

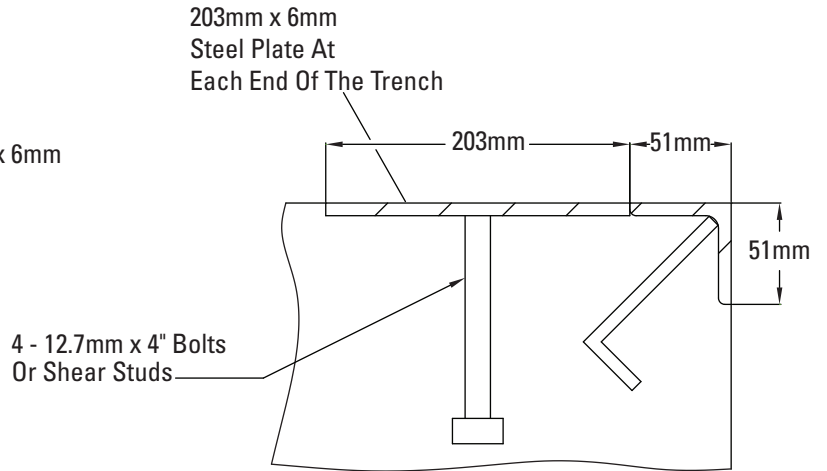

Steel Plate And Trench Edging Detail

NOTE 1:

The concrete reinforcement sizes and reinforcement specifications for the side walls and base of the trenches shall be determined by an architect or engineer and shall be determined considering the soil conditions at the site and the applied loading.

NOTE 2:

The concrete reinforcement specifications for the floor slab around the trench shall be determined by the architect or engineer and should be determined considering the soil conditions and the applied vehicle loading. As a minimum, grade 60 welded wire fabric shall be used around the vicinity of the lift trench.

NOTE 3:

The reinforcing steel shall be placed in the base slab of each trench not to interfere with the anchor bolts. The lift is installed using drilled in place wedge bolt concrete anchors.

**DS700I RECESS DETAIL
OPTIONAL RECESS
FRAME**

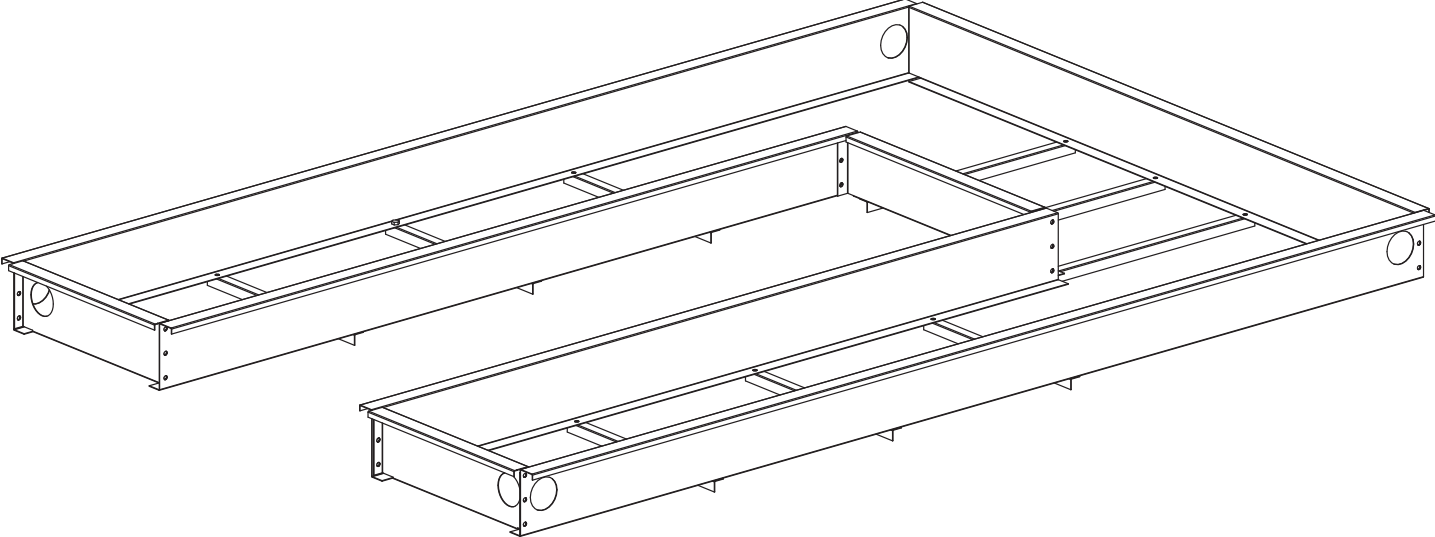

1.) Setting the Lift:

- Use architect's plan, when available, and the specifications in the first several pages to plan the service bay.
- Anchor the control console and install the power unit, Fig. 1a.
- Fill power unit with Dexron III ATF, or Hydraulic Fluid that meets ISO 32 specifications. Hydraulic schematic provided in the back of the manual.

2.) Hoses: Clean adapters and hose. Inspect all threads for damage and hose ends to be sure they are crimped. Install hose and hose clamps.

Flared Fittings Tightening Procedure

- Screw the fittings together finger tight. Then, using the proper size wrench, rotate the fitting 2-1/2 hex flats.

IMPORTANT Flare seat MUST NOT rotate when tightening. Only the nut should turn.

- Back the fitting off one full turn.
- Again tighten the fittings finger tight; then using a wrench, rotate the fitting 2-1/2 hex flats. This will complete the tightening procedure and develop a pressure tight seal.

CAUTION Overtightening will damage fitting resulting in fluid leakage.

3.) Electrical Connections:

- Connect photo-switch and travel switch cord, Figs. 2a and 2b.
- Connect electrical service to the lift, schematic provided in the back of the manual.

3.) Shop Air Connections:

- Connect shop air to air valve on back of control panel.
- Route air lines from lift and connect to air valve in the back of the control panel, 6-8 bar (85-115psi) required.

4.) Raise Lift:

- Raise lift, refer to Fig. 1b, high enough to access the anchor holes on the base plates of the lift, Fig. 3b.
- Lower lift to nearest safety lock.

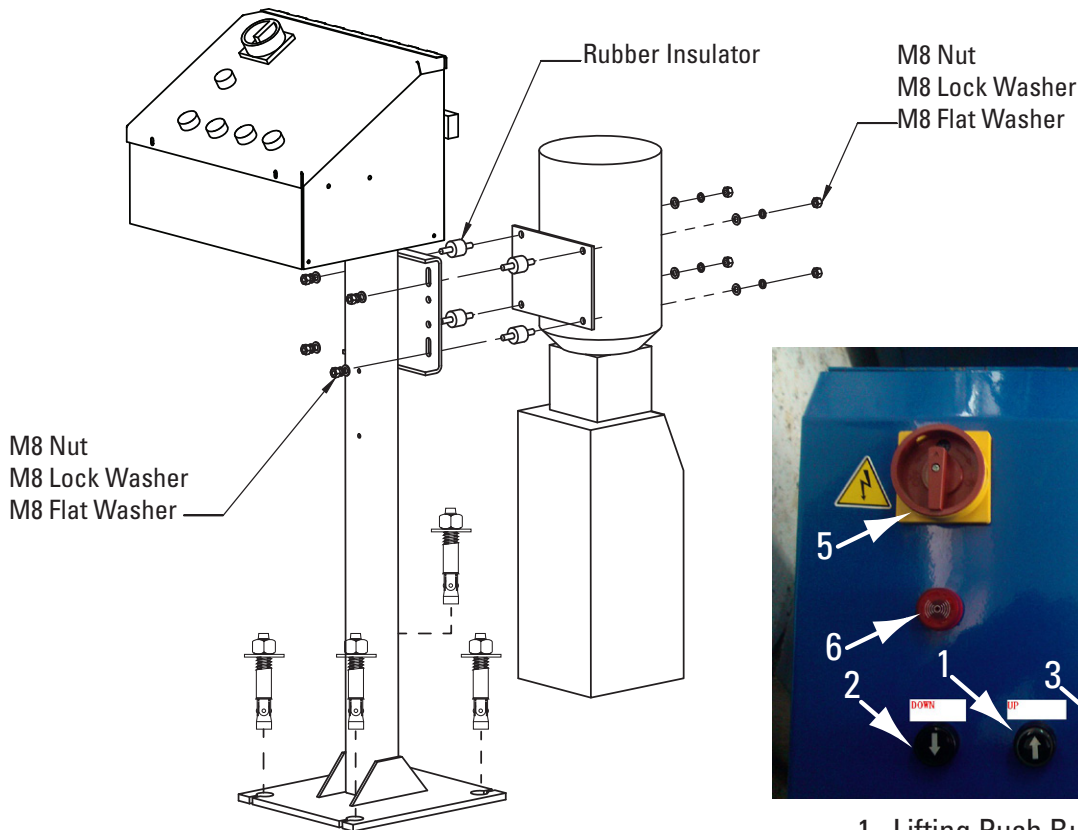
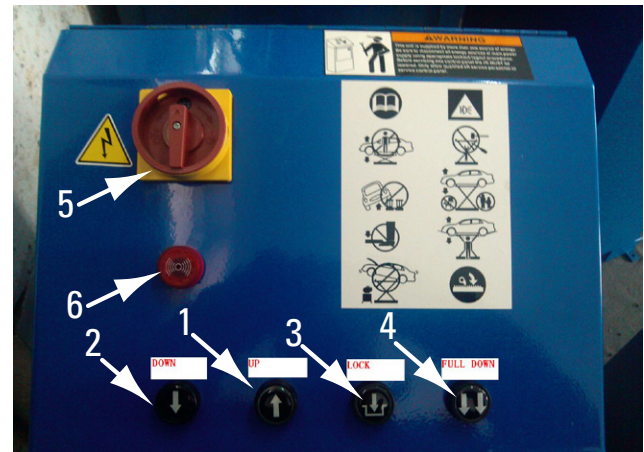
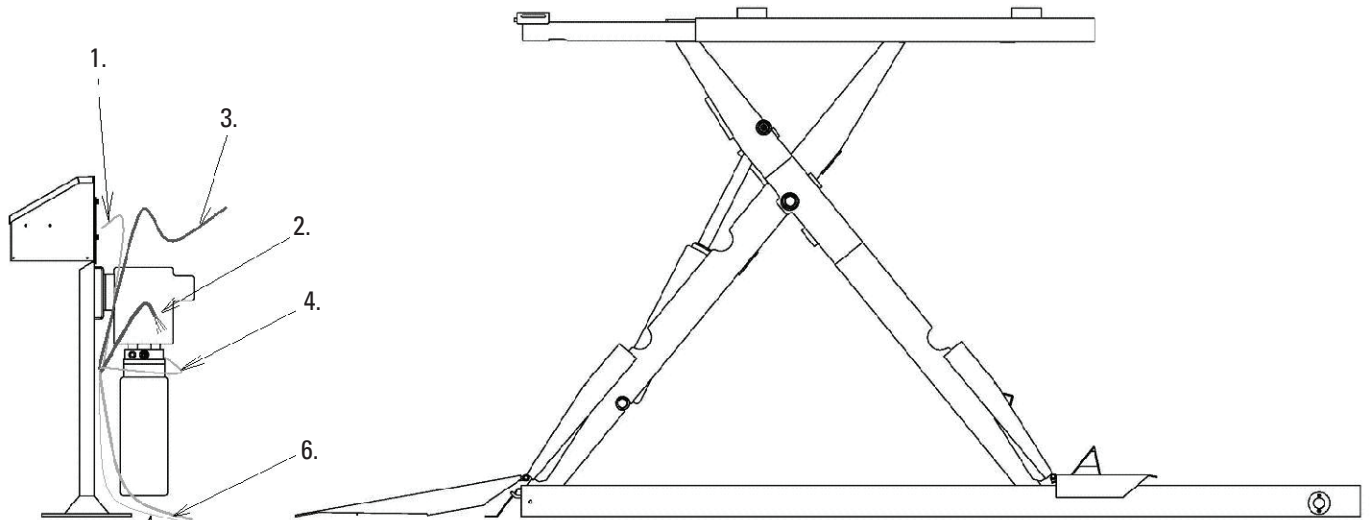

Fig. 1a



- Lifting Push Button
- Lowering Push Button
- Lower to Lock Button
- Full Down
- Master/Emergency Switch
- Beeper

Fig. 1b



- 1. Air Valve Cable
- 2. Motor Cable (U, V, W, PE)
- 3. Power Cable (L1, L2, L3, PE)
- 4. Oil Discharge Valve Cable
- 5. Photo Switch Cable And Lower Position Switch Cable
- 6. Ground Cable (PE)

Fig. 2a

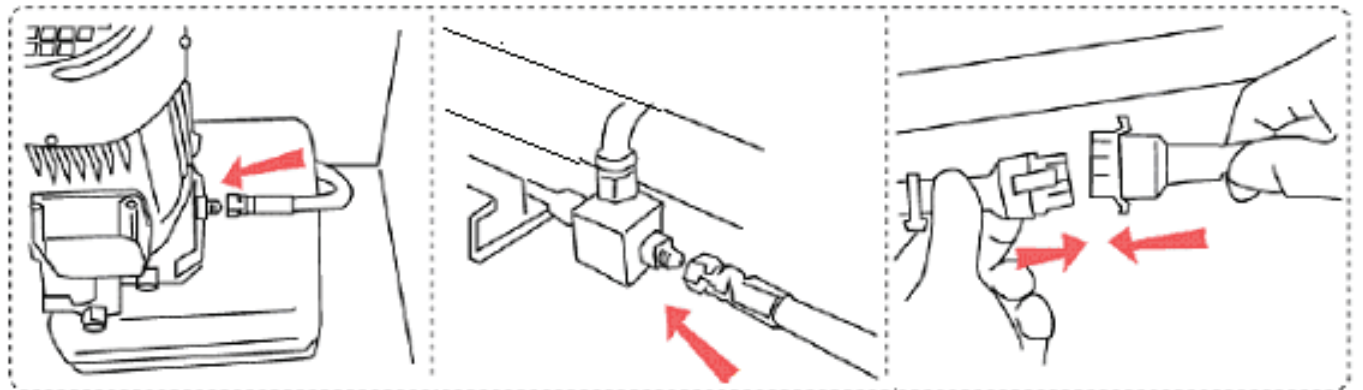

Connect Hydraulic Hose To The Power Unit

Connect Hydraulic Hose To The Lift

Connect Photo-Switch And Travel Switch Cord

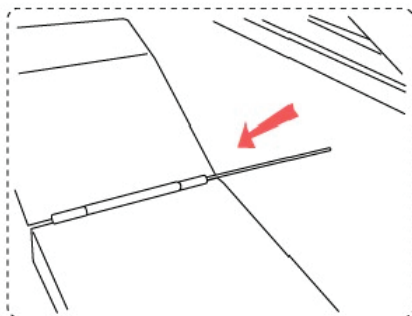

Connect Ramps

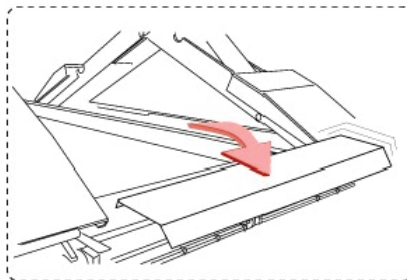

Place Cover Plate

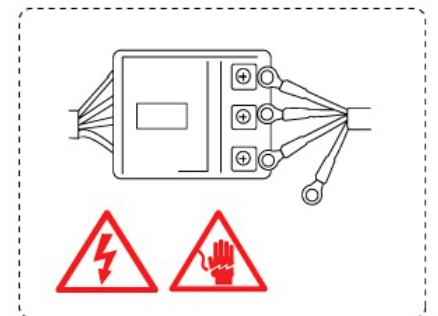

Connect Electrical Power

Fig. 2b

5.) Anchoring the lift:

- a. Using the base plate as a guide drill anchor holes, Figs. 3a, 3b and 3c.
- b. Before fully tightening down the anchor bolts use a level and check the lift at several locations along the base plates of the lift, Fig. 3d.
- c. Shim accordingly to level the lift.
- d. Once lift is level finishing tightening down the anchors, Fig. 3c.

IMPORTANT If anchors pull out of the floor or won't tighten then a new floor must be poured under the lift area.

6.) Lift operation:

- a. Raise and lower lift several time to make sure the lift is operating correctly.
- b. Refer to operations manual if problems occur.

CONCRETE AND ANCHORING REQUIREMENTS	
STANDARD	ANSI/ALI ALCTV-2011
Minimum Floor Thickness	4-1/4 INCHES
Anchor	Hilti Kwik Bolt III 3/4" x 5-1/2" Anchors supplied with the lift.*
Minimum Concrete Strength	3000 PSI
Minimum Anchor Embedment	3-1/4 INCHES
Minimum Distance to Concrete Edge, Crack, Expansion Joint, Abandoned Anchor Hole	4-1/2 INCHES

Fig. 3a

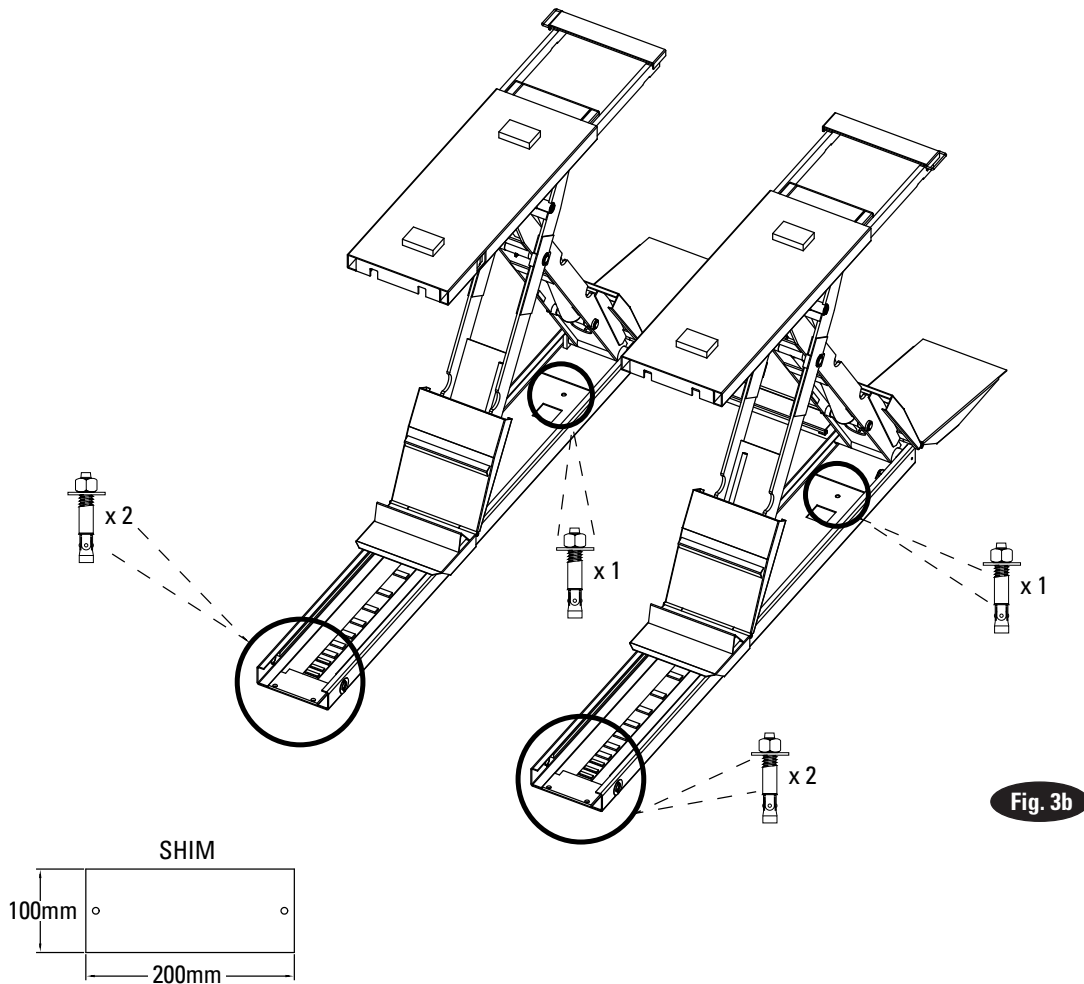
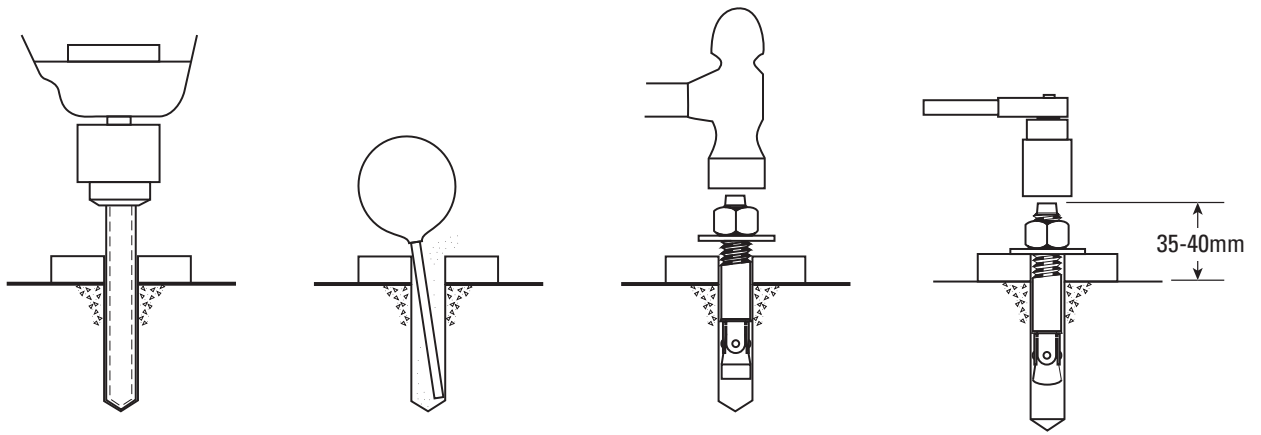

Fig. 3b



Drill holes using 3/4" carbide tipped masonry drill bit per ANSI B212.15-1994 (R2000)

Clean hole.

Run nut down just below impact section of bolt. Drive anchor into hole until nut and washer contact base.

Tighten nut with Torque wrench to 150 N-m

Fig. 3c

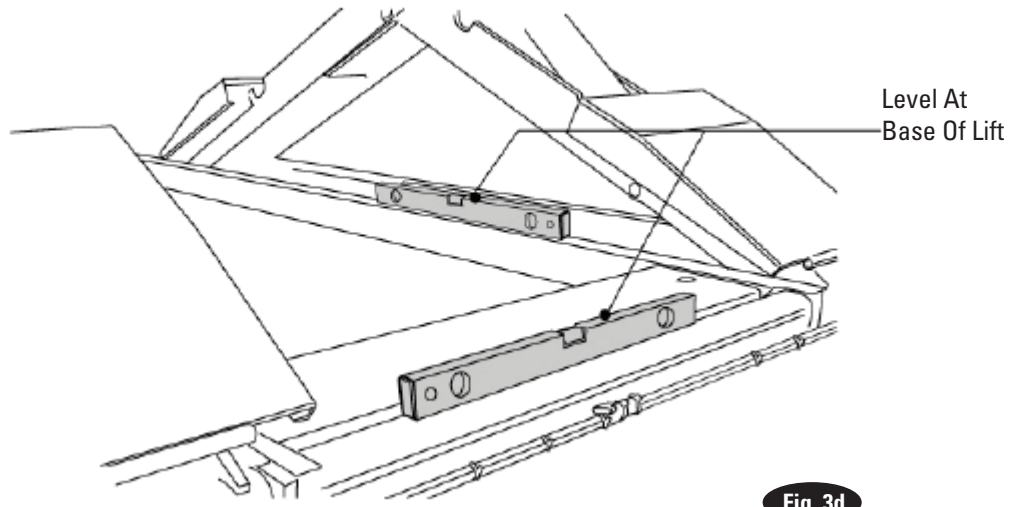
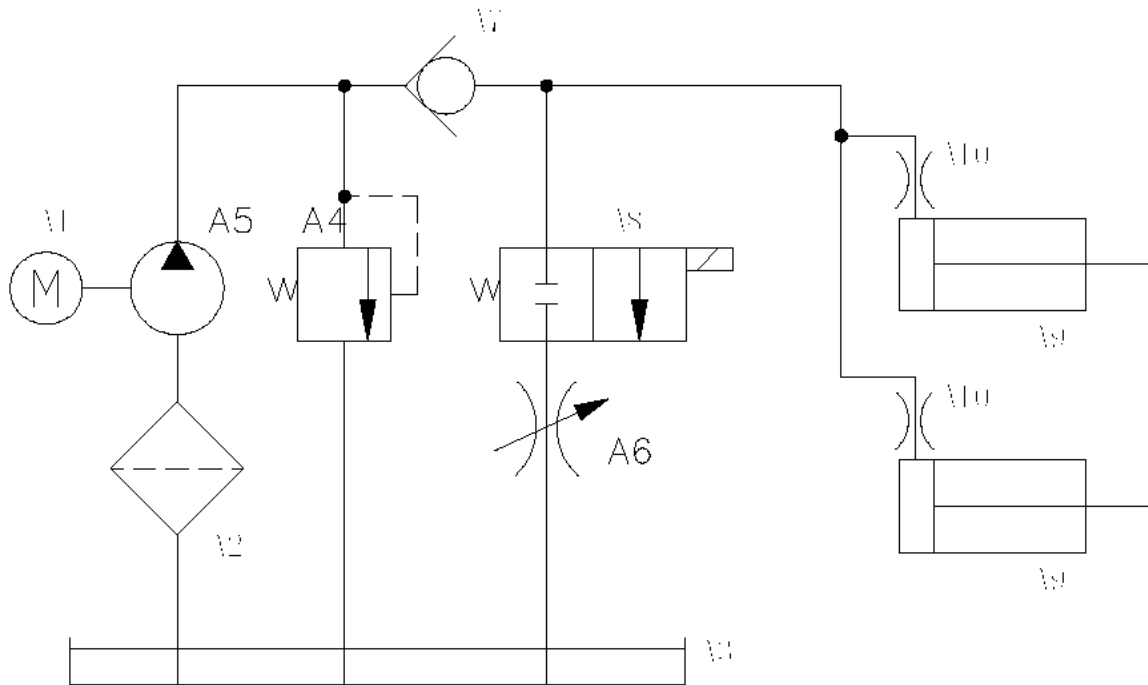

Fig. 3d

Hydraulic Schematic



S/N	Item	Type	Specifications	Piece	Remarks
A1	Motor		3Φ 380V, 50Hz, 2.2Kw	1	
A2	Hydraulic filter			1	
A3	Hydraulic tank			1	Volume 10L
A4	Overflow valve			1	
A5	Hydraulic pump			1	
A6	Return throttle valve			1	
A7	Check valve			1	
A8	Solenoid valve			1	
A9	Hydraulic cylinder			2	
A10	Lowering throttle valve			2	

Single Phase Electrical Schematic

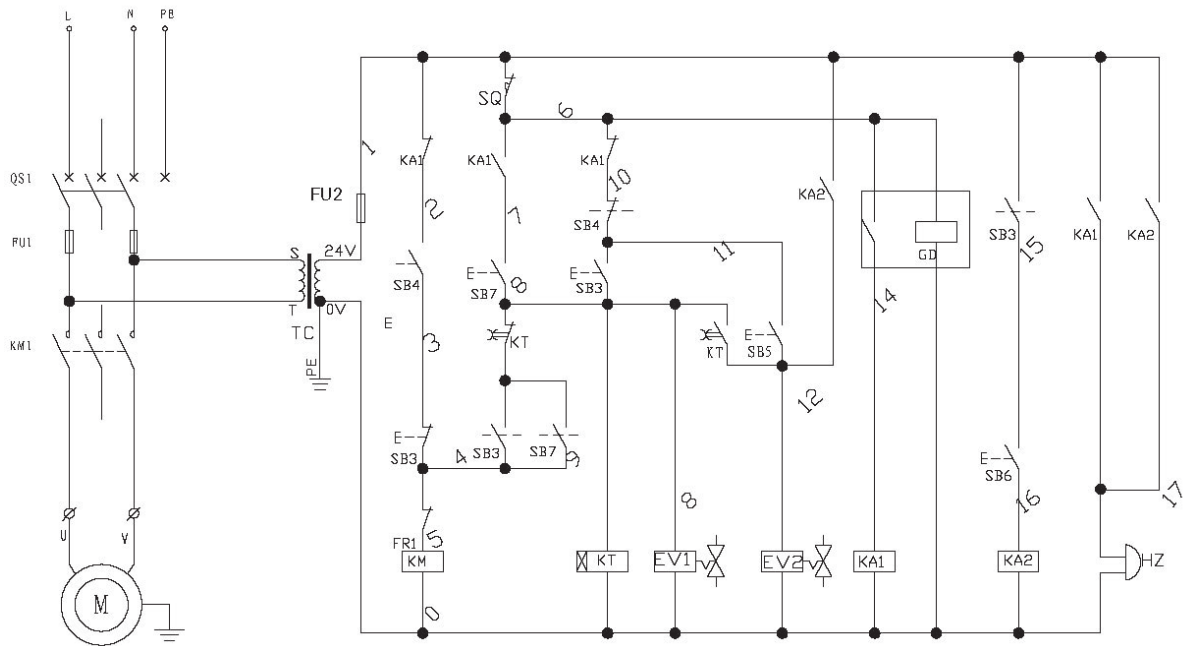

- SB3 Lowering button (black)
- SB4 Raise button (white)
- SB5 Lock (green)
- SB6 Final lowering button (black)
- SB7 Emergency button (red)
- EV1 Relief valve
- EV2 Air valve
- HZ Buzzer
- GD Photo-switch
- SQ Travel switch

Three Phase Wiring Schematic

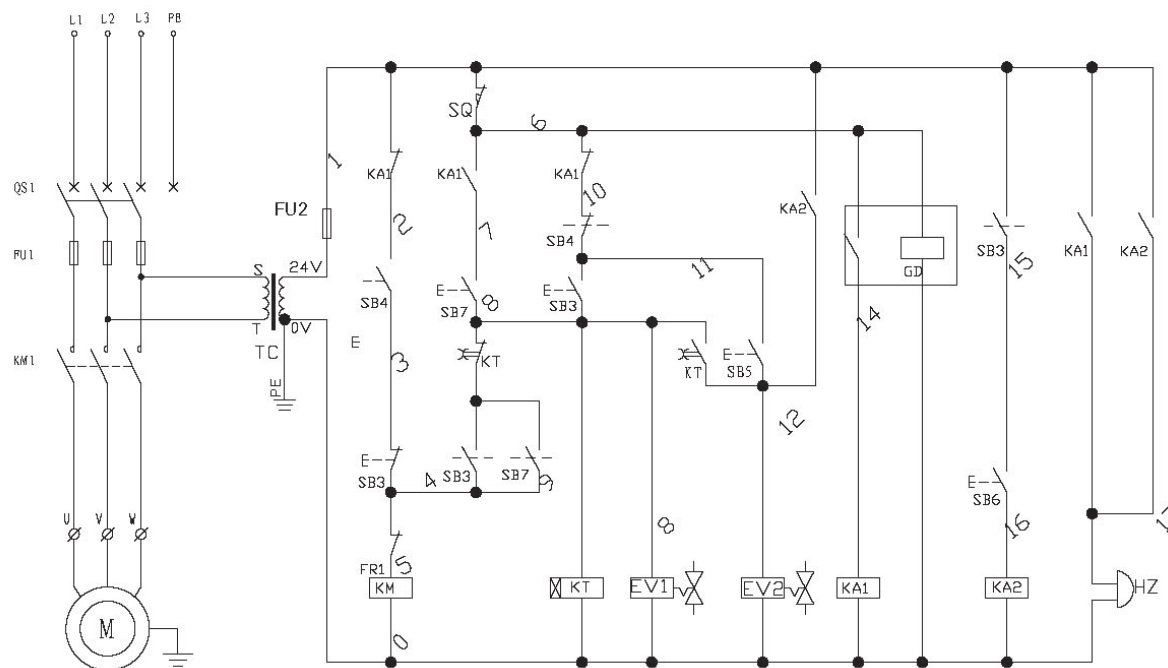

- SB3 Lowering button (black)
- SB4 Raise button (white)
- SB5 Lock (green)
- SB6 Final lowering button (black)
- SB7 Emergency button (red)
- EV1 Relief valve
- EV2 Air valve
- HZ Buzzer
- GD Photo-switch
- SQ Travel switch

NOTES:

NOTES:

NOTES:

Vehicle Service GroupSM
2700 Lanier Drive
Madison, IN 47250, USA
1-800-640-5438
www.vsgdover.com



© **Vehicle Service GroupSM**
All Rights Reserved. Unless otherwise
indicated, **Vehicle Service GroupSM**
and all other trademarks are property
of Dover Corporation and its affiliates.