



CR4T

Installation Instructions

**Capacity 4082 kg (9000 lbs)
2041kg (4500 lbs) per axle**

**Maximum Wheelbases: 3861mm (152")
Minimum Wheelbase At Rated Capacity: 2515mm (99")**

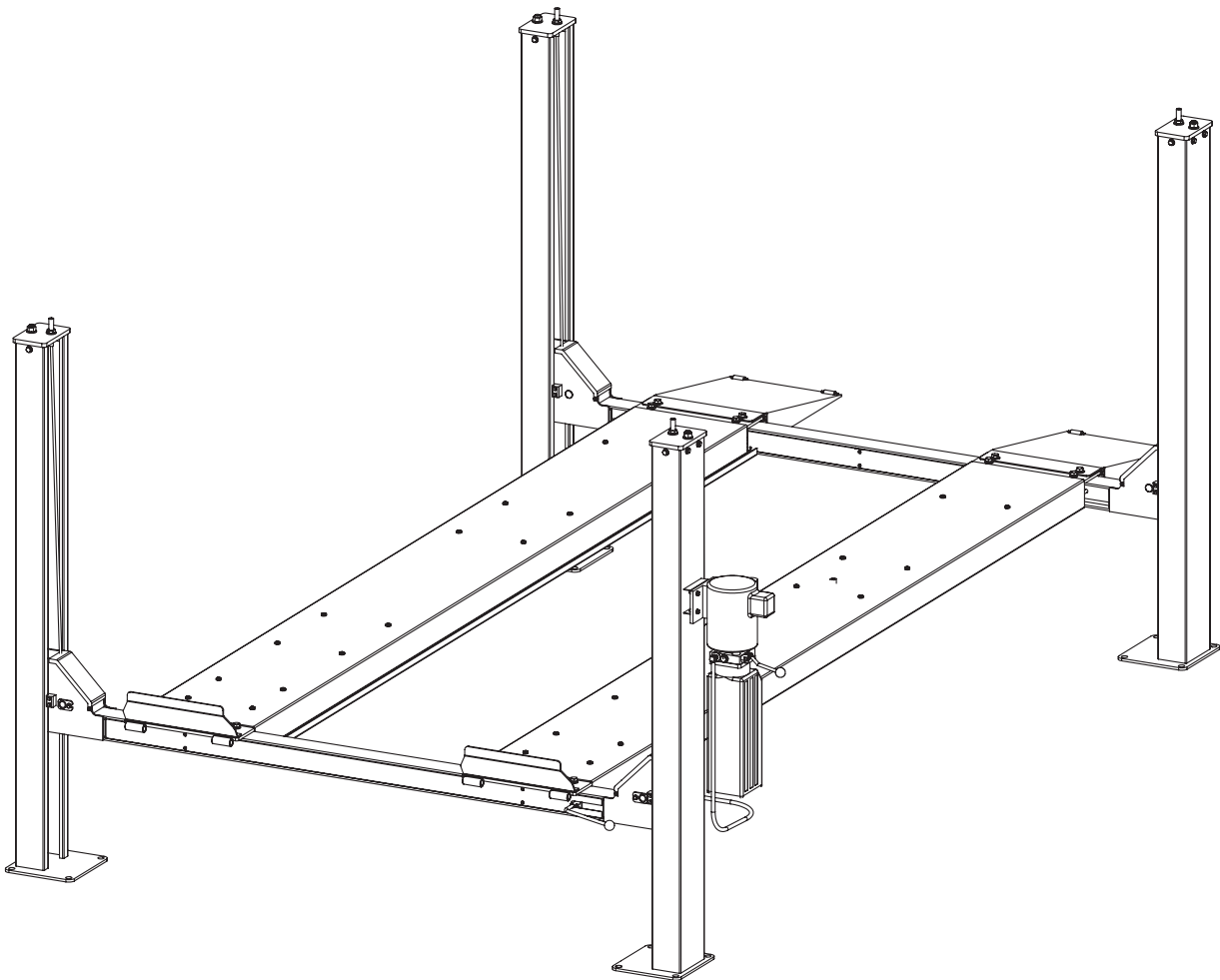

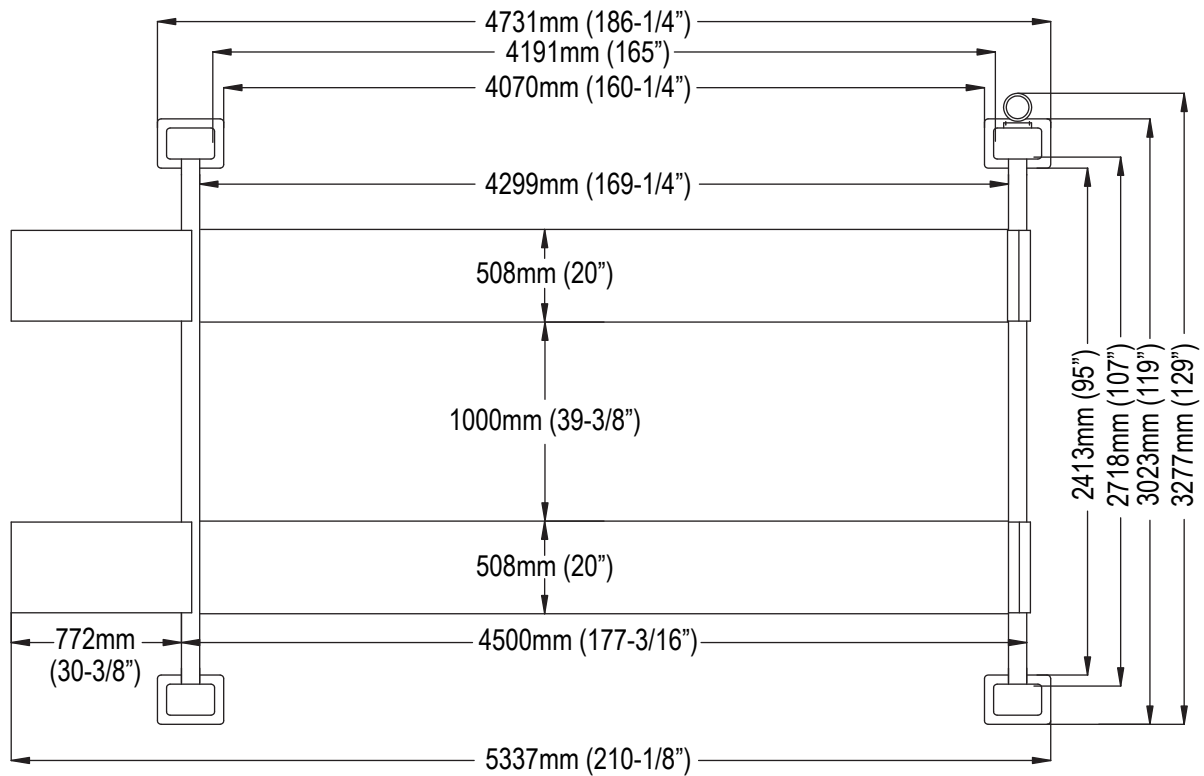

YOU WILL NEED A MIN. OF 15' (4572mm) CLEARANCE IN REAR TO INSTALL "T" ROD

Fig. 1

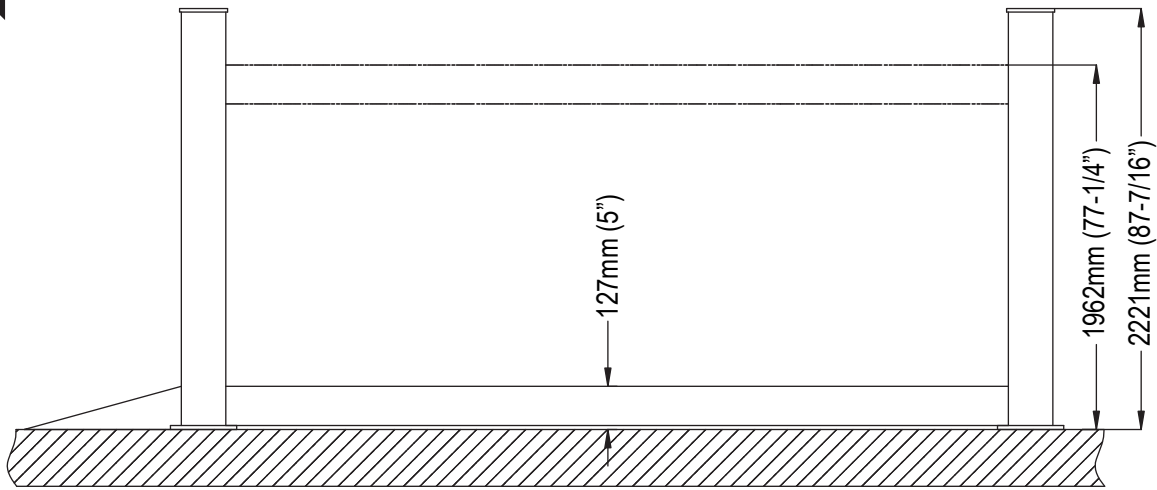

SPECIFICATIONS

- At full rise 1962mm (77-1/4")
- Baseplate to baseplate length 4731mm (186-1/4")
- Baseplate to power unit width 3277mm (129")
- Column height 2221mm (87-7/16")
- Width of runways 508mm (20")
- Height of runways 127mm (5")
- Width between runways 1000mm (39-3/8")
- Lift Capacity 4082 kg (9000 lbs)

Safety

Wear work gloves, steel toed shoes, and safety glasses during the installation of your lift.

IMPORTANT Avoid drug or alcohol use that will impair your ability to install or operate your lift.

⚠ DANGER Improper installation or improper use of your lift could cause serious injury or death. Read installation instructions and owner's manual thoroughly before installing or operating your lift.

Unloading And Unpacking Your Lift

The components for your lift are heavy. The runways for these lifts weigh in excess of 182 kg (400 lbs) each. The preferred method for unloading your lift is by forklift.

If a forklift is not available a minimum of (4) people able to lift 57 kg (125 lbs) EACH will be needed to unload and assemble your lift.

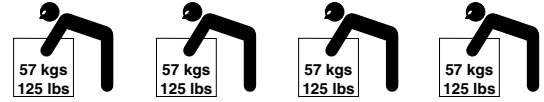

⚠ CAUTION Shipping bands around packages are under extreme tension. Have everyone stand clear when cutting shipping bands.

Note: Use personal protective equipment as required - Lift smart using preferred methods. See your Lifting It Right Manual, page 23.

Examine each lift component as you unload it to check for shipping damage.

A Quick Overview Of Your Lift

Remember! Prepare A Location For Your Lift Before You Unload It From The Truck.
Location Should Be A Level Surface.

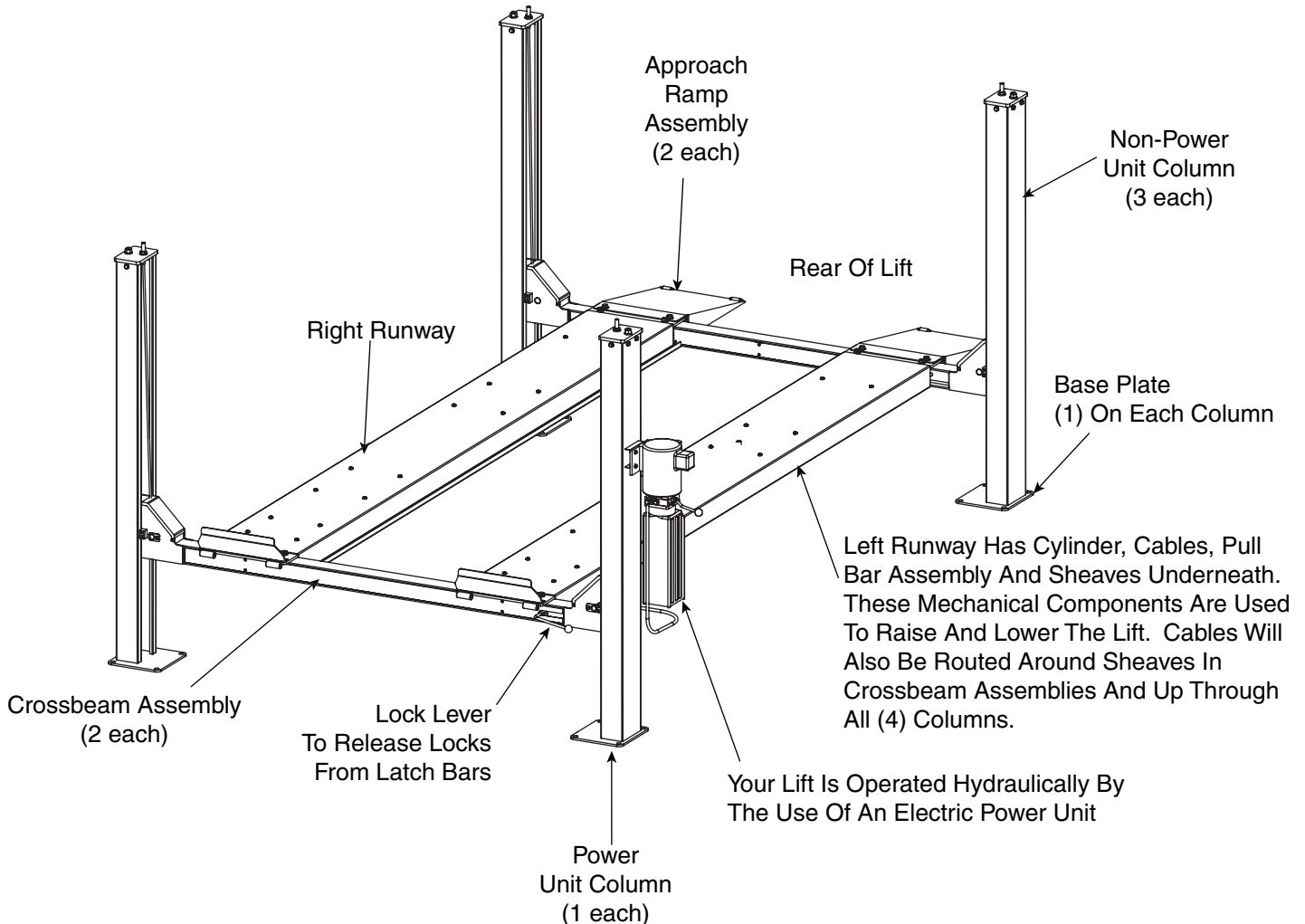

Step 1: Setting Runways:

- A.) If you haven't read previous pages, go back and do so now.
- B.) Place runways in desired location according to Fig. 3.

Note: The runways weigh in excess of 182kg (400 lbs). Use a minimum of 4 people to move these runways.

Attention! Use 4 People To Place Runways

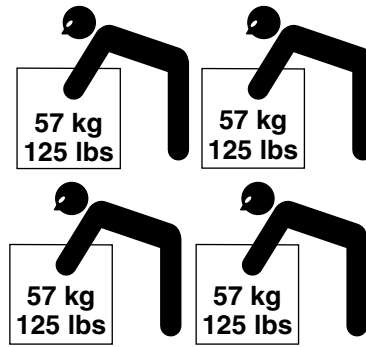

Fig. 2

Step 2: Placing Columns:

- A.) Place columns around runways as shown, Fig. 3. NOTE: Dimensions are reference only to get the columns placed in their approximate location. This will help to keep from moving around as much in future steps.

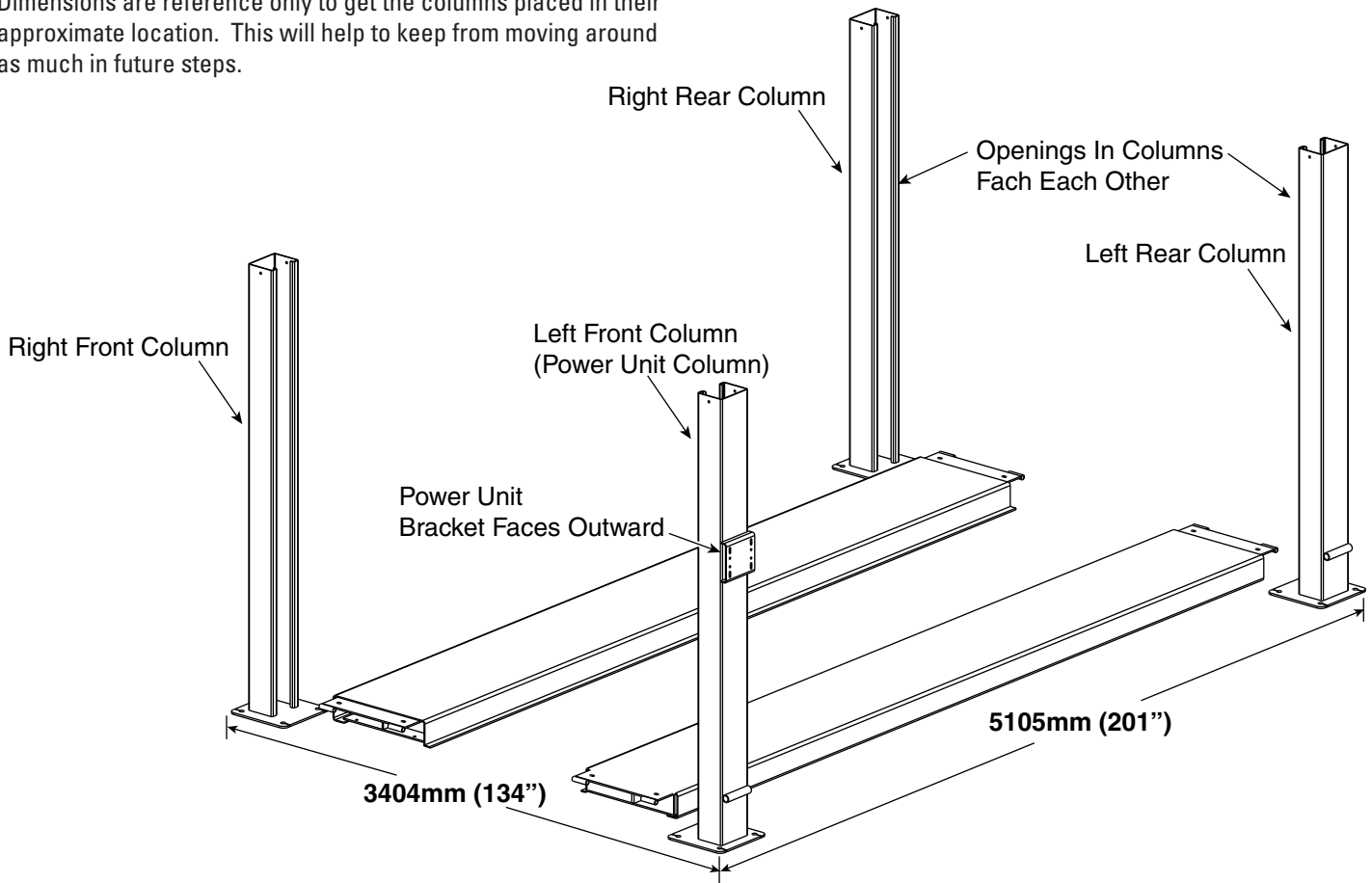

Fig. 3

Step 3: Installing Latch Bar:

A.) Remove Column Top Plate as shown, Fig. 4.

B.) Install Rub Blocks as shown using M8 x 20 Socket Head Cap Screw in location shown. Note orientation. The thick area will always be to the inside of the lift.

C.) Place crossbeams on ground between columns.

IMPORTANT NOTE ORIENTATION OF CROSSBEAMS. THE SIDE OF THE CROSSBEAM WITH THE SHORT SIDE COVER GOES

TOWARDS THE INSIDE OF THE LIFT. THE CROSSBEAM WITH THE FULL LENGTH SIDE COVER GOES TO THE OUTSIDE. THIS IS CRITICAL FOR CABLE INSTALLATION.

D.) Slide columns into crossbeams until it hits the rub blocks.

E.) Insert (1) latch bar into each column. Be sure to slide through Retainer as shown, Fig. 5. The bottom of the latch bar will insert into the slot on the baseplate of the column.

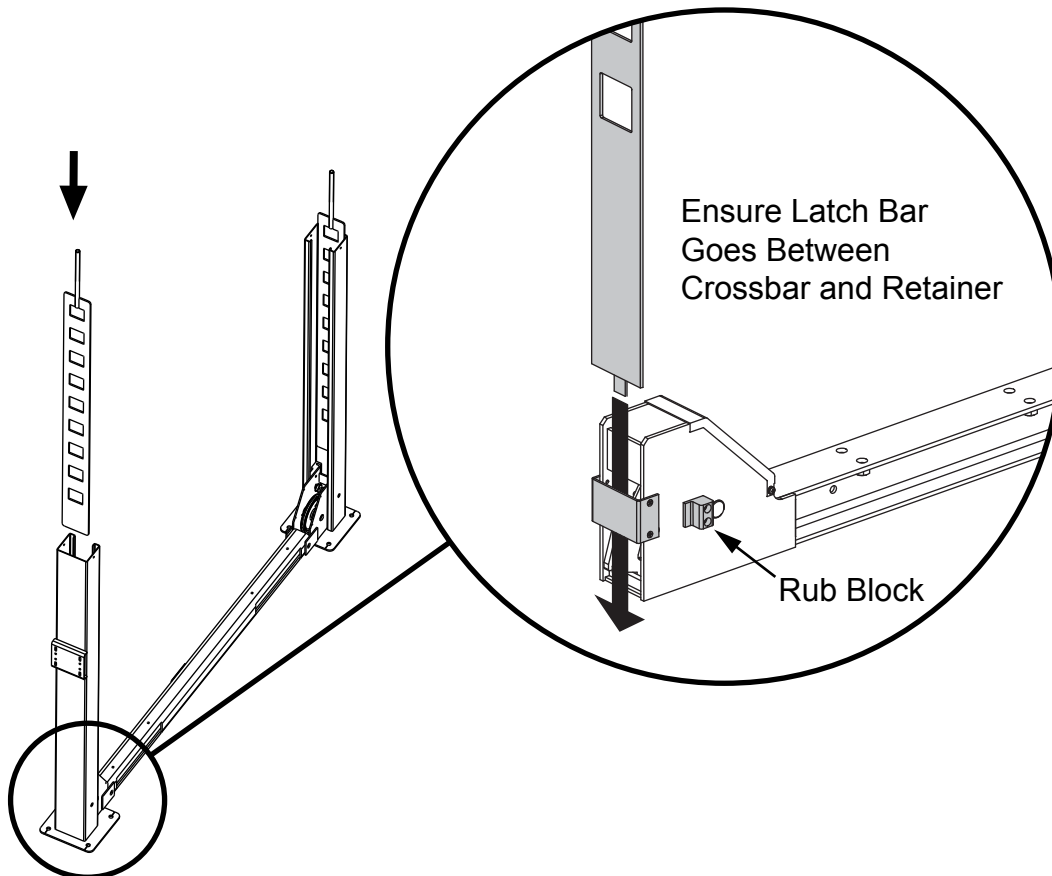
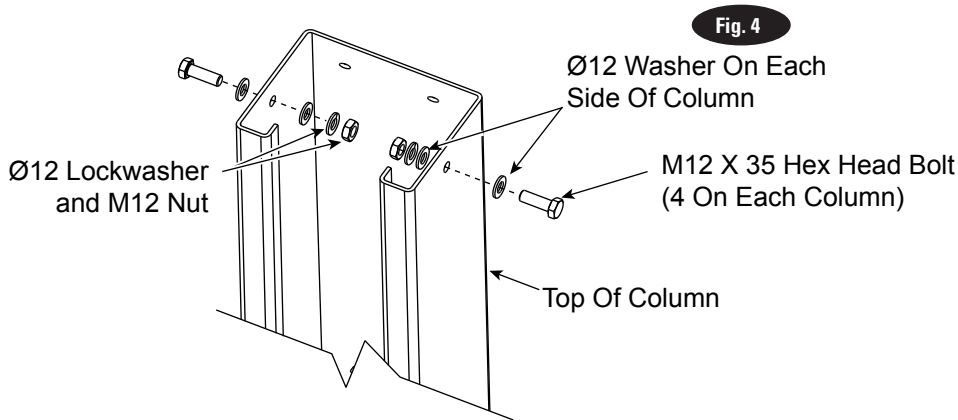
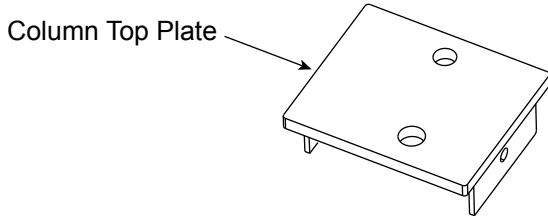

Fig. 5

Step 4: Reinstalling Column Top Plates:

A.) Install (1) column top plate in each column, Fig. 6. Make sure latch bar jam nut is located far enough down the latch bar stud to allow you to fully insert the column top plate in the top of the column.

B.) After column top plates have been installed adjust latch bar nut and latch bar jam nut as shown, Fig. 7.

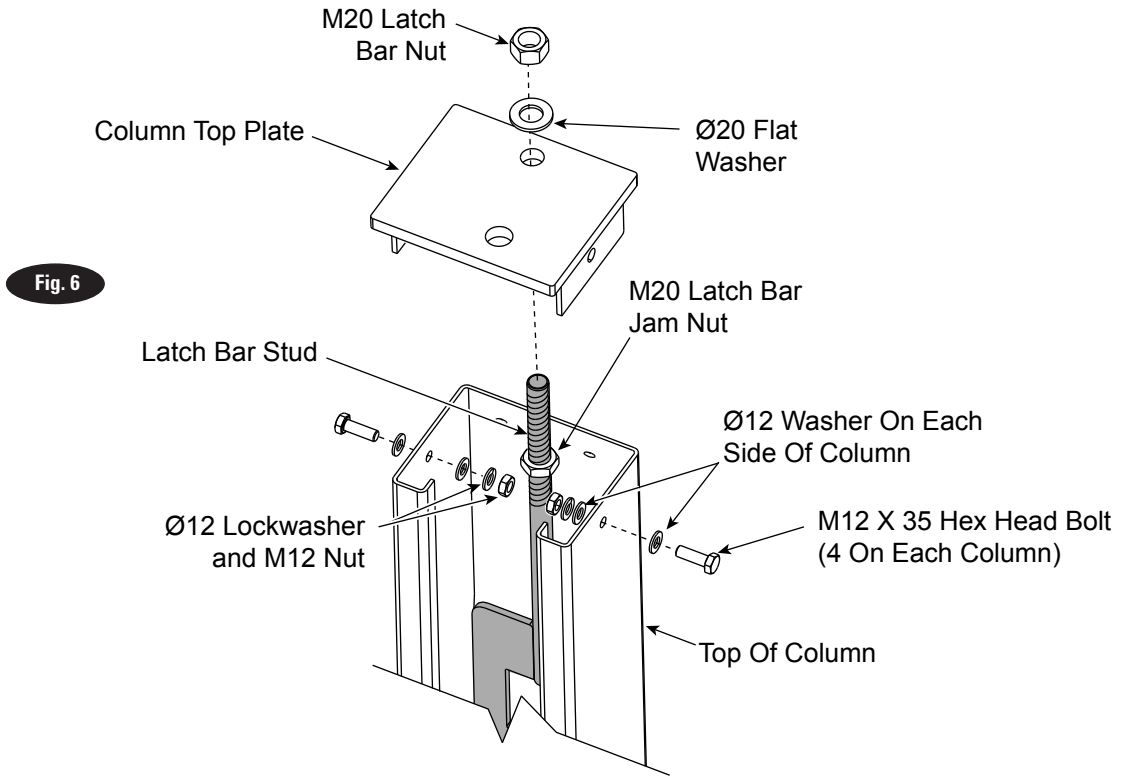

Fig. 6

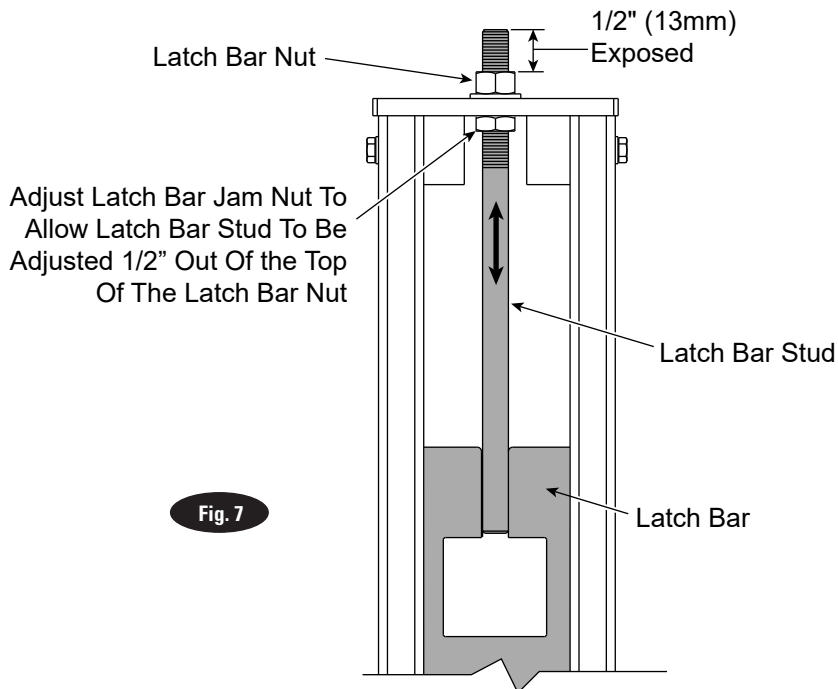

Fig. 7

Step: 5: Runway Installation (columns not shown for clarity):

A.) Use a minimum of (2) people to raise crossbeam assemblies to first lock.

B.) Remove inside short crossbeam covers, Fig. 8.

C.) Using a mechanical device such as pulley or winch come along, fully extend hydraulic cylinder (located under runway).

D.) Being careful not to cross or pinch cables, install runway to crossbeams as shown, Fig. 9 & Fig. 10.

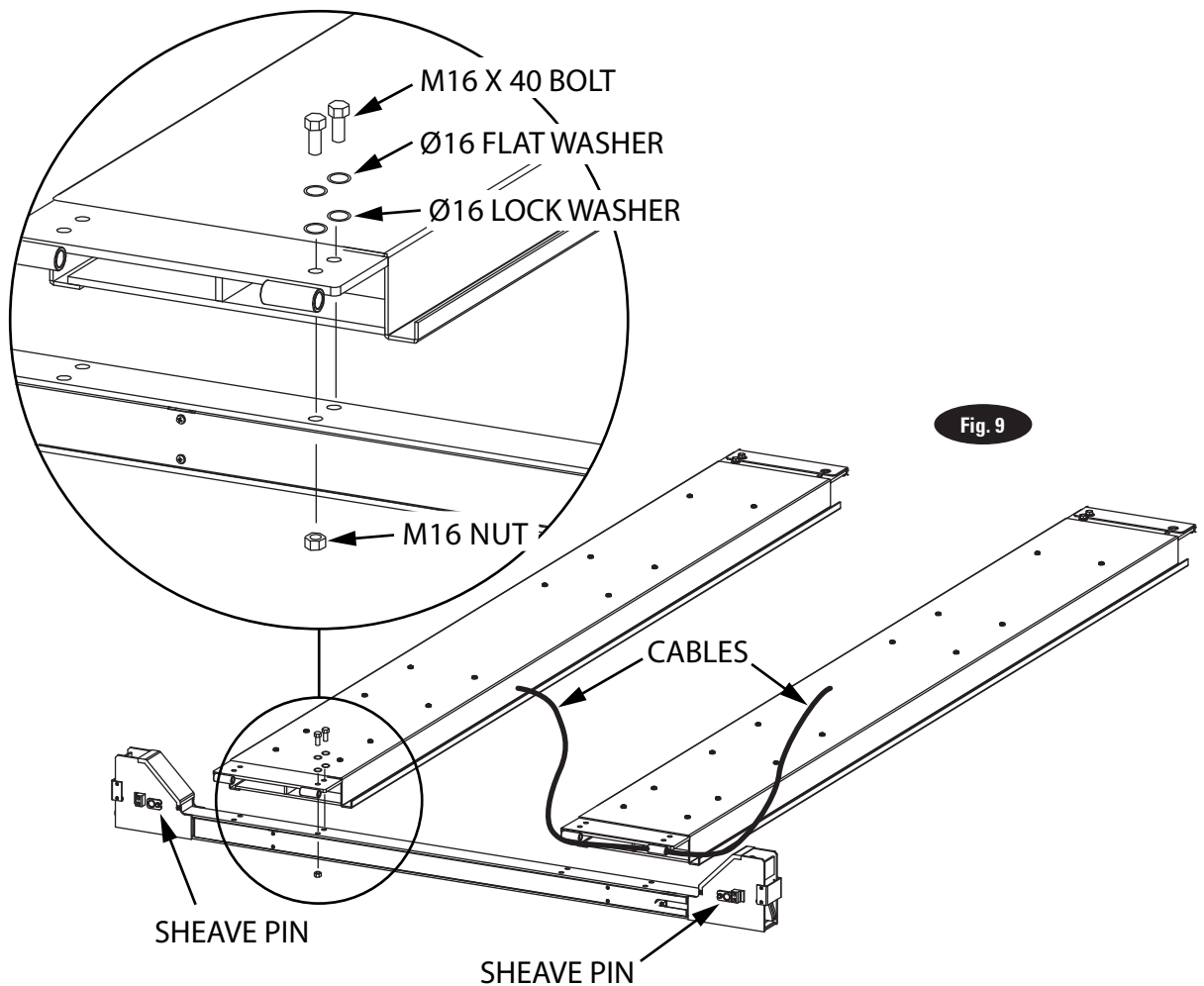
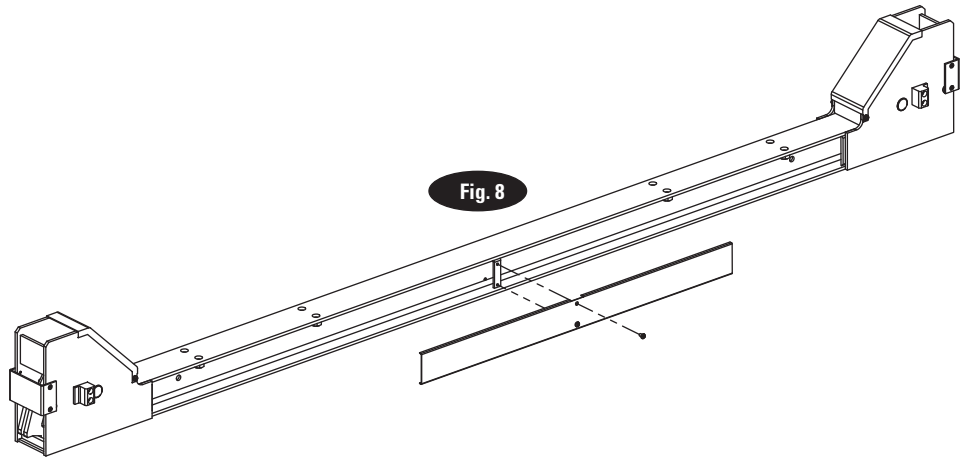

IMPORTANT It is very important that the cables and sheaves in yoke assemblies get installed properly. Failure to do so will cause damage to your lift!

Step 6: Cable Routing:

A.) Route cables from runway to each column. When running cable across the crossbeam, be sure cables run behind center

bar, Fig. 11. Run cables up each column keeping the cables on the inside of the slack cable actuators, Fig. 10. You will need to remove the Sheave Pins, Fig. 9 and Sheave, Fig. 10 in order to get the cable routed properly. Once routed, re-install sheaves and spacers.

B.) Attach cable studs to column top plates, Fig. 12.

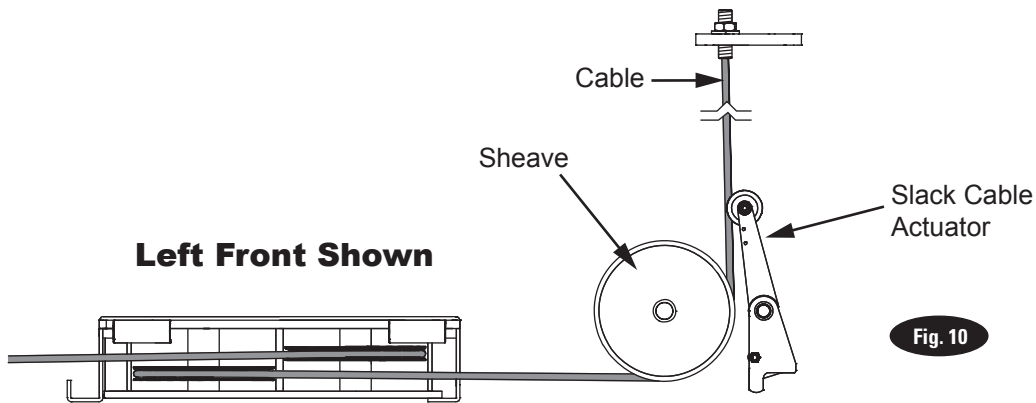

Fig. 10

IMPORTANT MAKE SURE CABLES DO NOT GET CROSSED

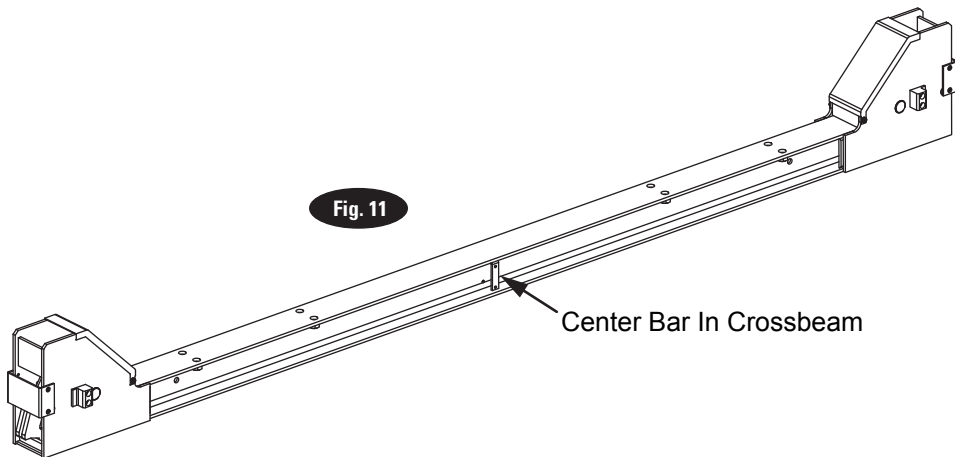

Fig. 11

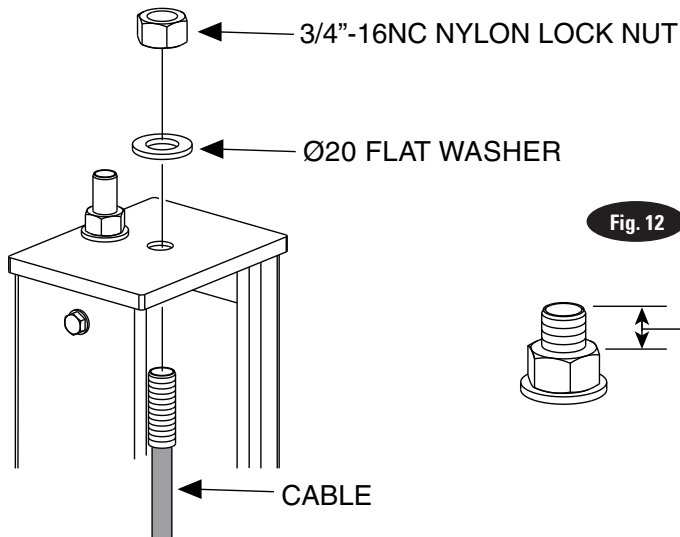
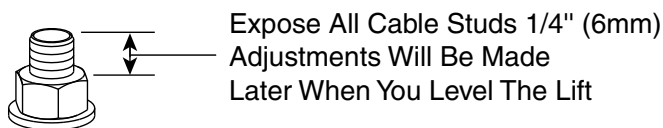
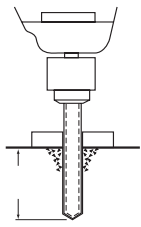

Fig. 12



IMPORTANT PUSH COLUMNS UP TIGHT AGAINST RUB BLOCKS BEFORE DRILLING OR ANCHORING LIFT COLUMNS



Drill holes using 3/4" carbide tipped masonry drill bit per ANSI standard B94.12.1977

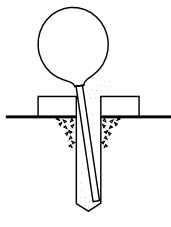

Clean hole.

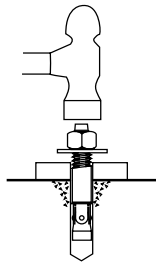

Run nut down just below impact section of bolt. Drive anchor into hole until nut and washer contact base.

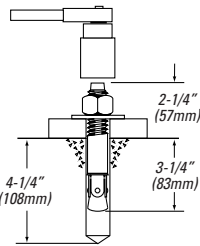

Tighten nut with Torque wrench to 110 ft-lbs. (149 Nm)

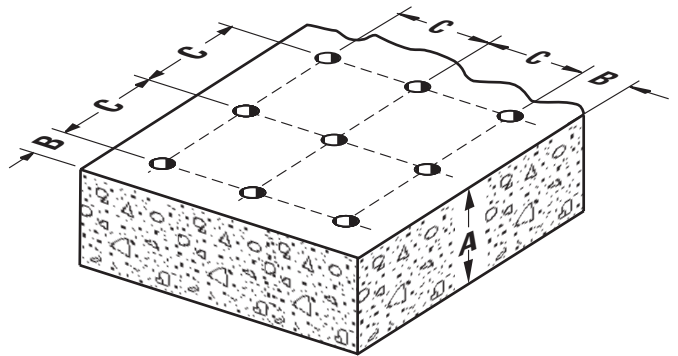

- A) Concrete Thickness & Hole Depth 4-1/4" (108mm)
- B) Edge Distance 4-3/4" (121mm)
- C) Hole Spacing 6-1/2" (165mm)

Installation torque of 110 ft-lbs. (149 Nm) is required for all anchor bolts.

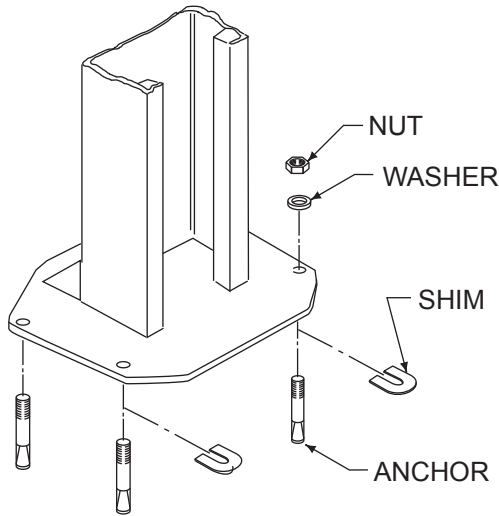

NOTE: If more than 2 horse shoe shims are used at any of the column anchor bolts, pack non-shrink grout under the unsupported area of the column base. Insure shims are held tightly between the baseplate and floor after torquing anchors.

Step 7: Concrete and Anchoring: Concrete shall have a compression strength of at least 3,000 PSI (20684 kPa.) and a typical slab thickness of 5-1/2" (140mm) to 6" (140mm). In order to achieve required anchor loads, a minimum concrete thickness of 4-1/4" (108mm) and anchor embedment of 3-1/4" (83mm) is required at each anchor location. When using the standard supplied 3/4" x 5-1/2" (19 x 140mm) lg. anchors, if the top of the anchor exceeds 2-1/4" (57mm) above the floor grade, you DO NOT have enough embedment.

Drill 3/4" dia. holes in concrete floor using holes in column base plate as a guide. See Figures above for hole depth, hole spacing, and edge distance requirements.

IMPORTANT PUSH COLUMNS UP TIGHT AGAINST RUB BLOCKS BEFORE DRILLING OR ANCHORING LIFT COLUMNS.

CAUTION DO NOT install on asphalt or other similar unstable surfaces. Columns are supported only by anchors in floor.

IMPORTANT Using the horse shoe shims provided, shim each column base until each column is plumb. If one column has to be elevated to match the plane of the other column, full size base shim plates should be used. Recheck columns for plumb.

IMPORTANT PUSH COLUMNS UP TIGHT AGAINST RUB BLOCKS BEFORE DRILLING OR ANCHORING LIFT COLUMNS.

Tighten anchor bolts to an installation torque of 110 ft-lbs. (149 Nm). Shim thickness MUST NOT exceed 1/2" (13mm) when using the 5-1/2" (140mm) long anchors provided with the lift. Adjust the column extensions plumb.

If anchors do not tighten to 110 ft-lbs. (149 Nm) installation torque, replace concrete under each column base with a 4' x 4' x 6" (1219 x 1219 x 1522mm) thick 3000 PSI (20684 kPa.) minimum concrete pad keyed under and flush with the top of existing floor. Let concrete cure before installing lifts and anchors.

Step 8: Installing Power Unit:

A.) Install power unit to power unit bracket, Fig. 13.

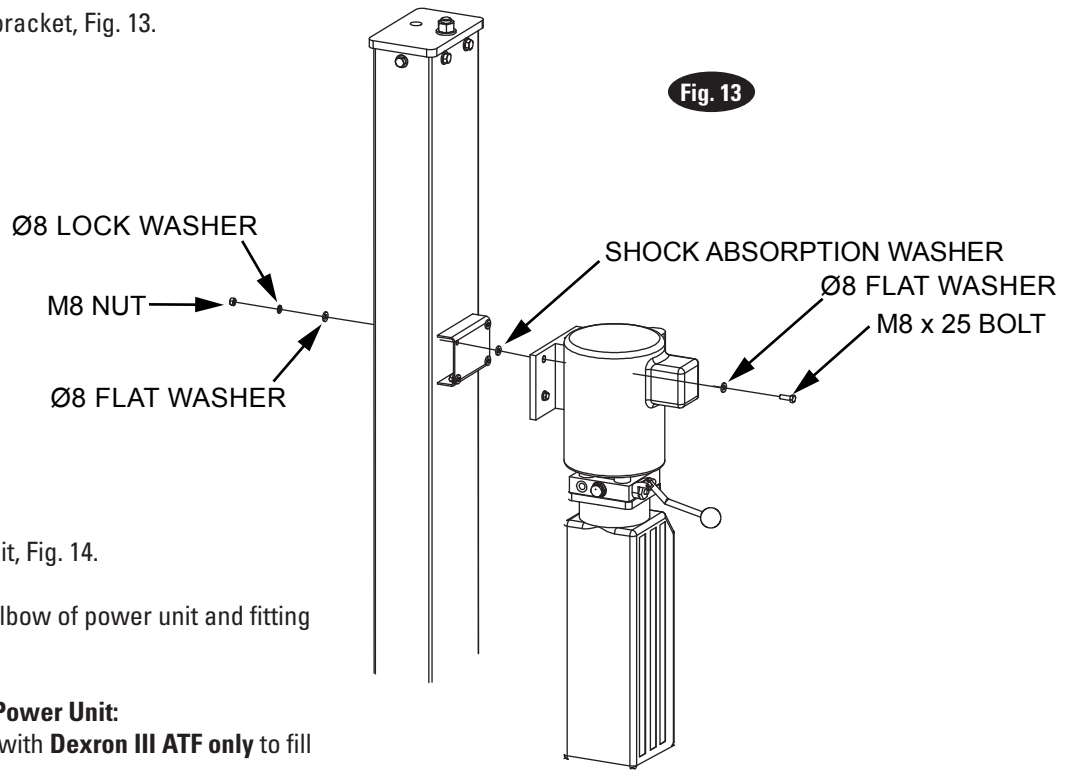

Step 9: Installing Hydraulic Hose:

A.) Attach 90° elbow onto power unit, Fig. 14.

B.) Install hydraulic hose onto 90° elbow of power unit and fitting in side of runway, Fig. 14.

Step 10: Adding Hydraulic Fluid To Power Unit:

A.) Remove fill/breather cap and fill with **Dexron III ATF only** to fill line on tank.

The capacity of the tank is approximately 12 liters.

Note: If fill/breather cap is lost or missing replace with original equipment replacement part.

IMPORTANT DO NOT substitute a different type of cap or plug.

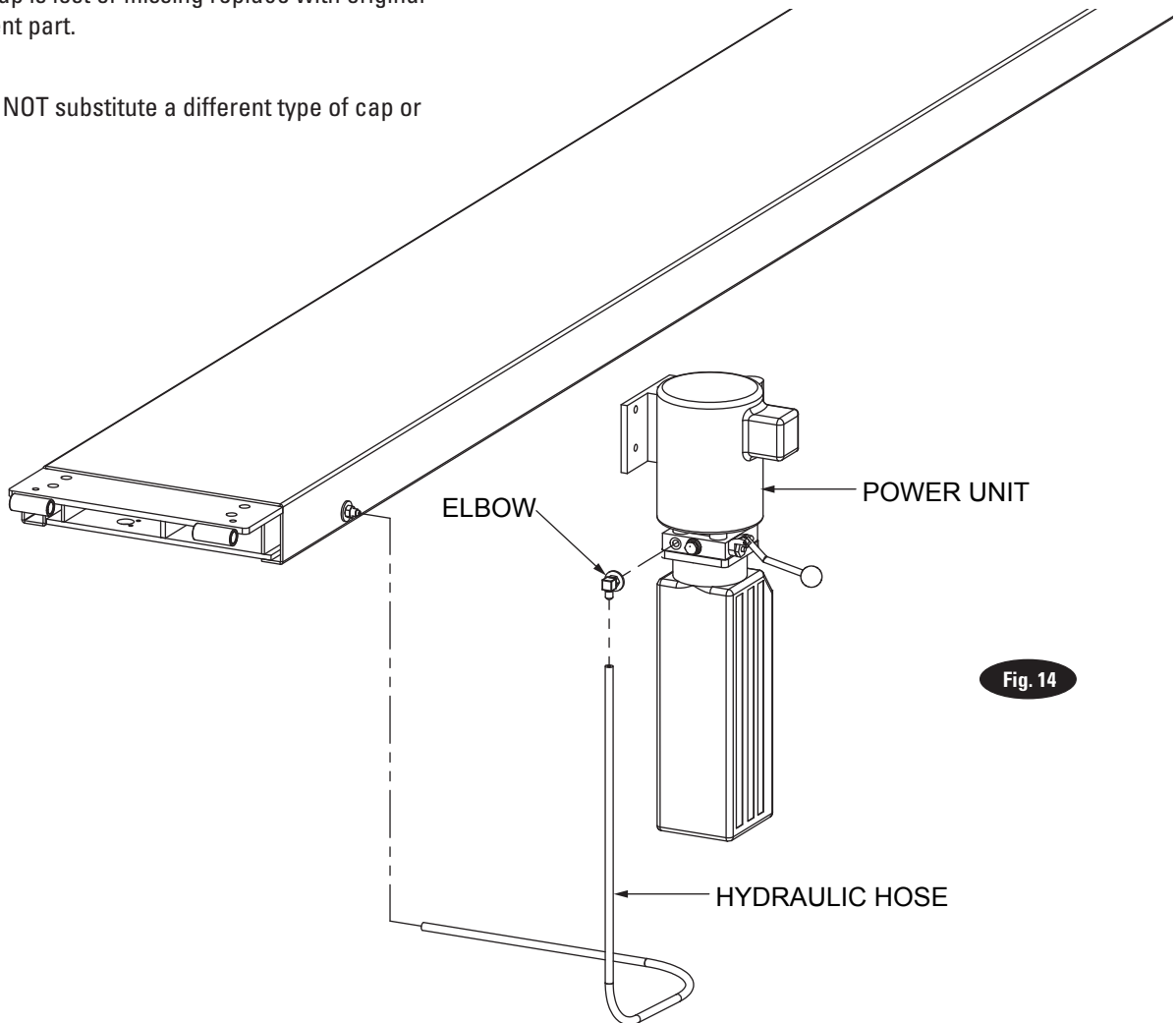

Step 11: Adapter and Hose Installation:

A.) Remove plug from power unit using hex wrench, Fig. 1 below.

B.) Install EPL6-03 3/8" NPT-1/4" 90° tube fitting, Fig. 2 below.

3. Connect hydraulic cylinder return line to tube fitting, Fig. 3 below.

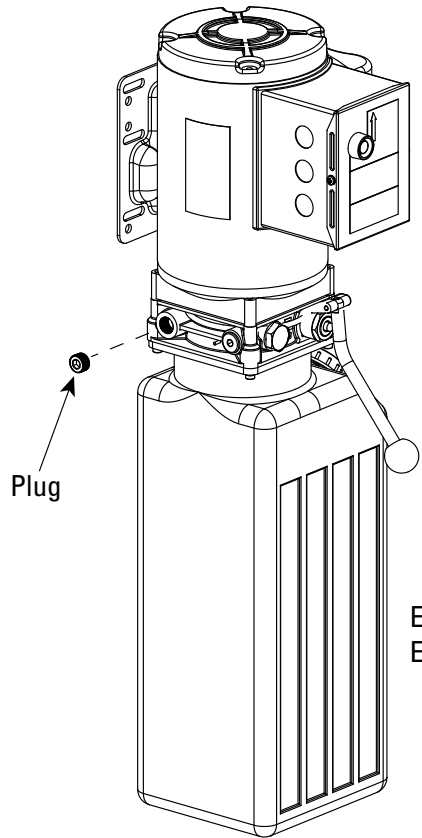

Fig. 1

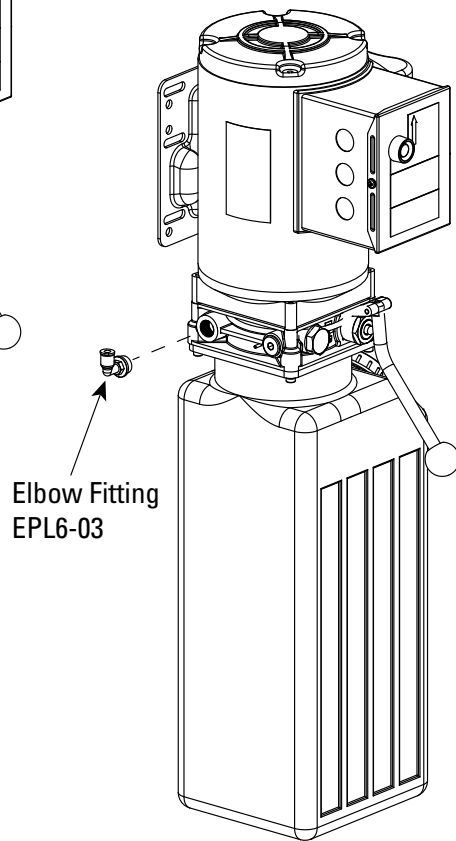

Fig. 2

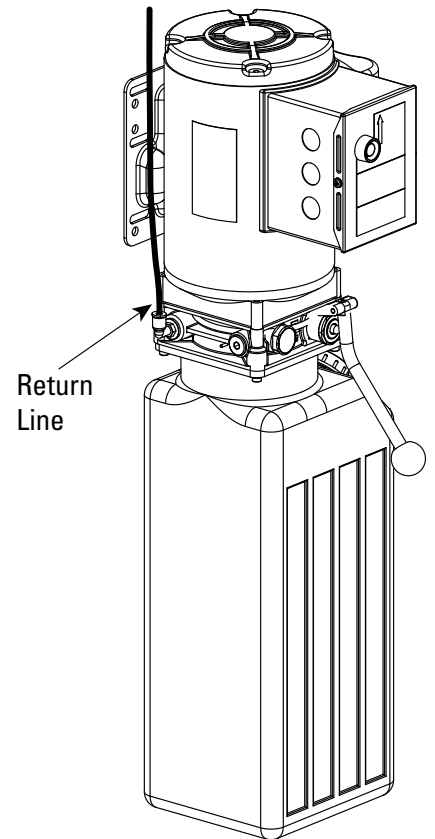

Fig. 3

Step 12: Electrical Service To Power Unit:

Have a certified electrician run appropriate power supply to motor. Size wire for 20 amp circuit. See Motor Operating Data Table.

CAUTION Never operate the motor on line voltage less than 208V. Motor damage may occur.

Single Phase Wiring

SINGLE PHASE POWER UNIT WIRING	
MOTOR OPERATING DATA - SINGLE PHASE	
LINE VOLTAGE	RUNNING MOTOR VOLTAGE RANGE
208V - 230V 60Hz	197V - 253V
208V - 230V 50Hz	197V - 253V



IMPORTANT: Use separate circuit for each power unit. Protect each circuit with time delay fuse or circuit breaker. For single phase 208-230V, use 20 amp fuse. Three phase 208-240V, use 20 amp fuse. For three phase 400V (*E Model) and above, use 10 amp fuse. For three phase 380V (*S Model) use 16 amp fuse. All wiring must comply with NEC and all local electrical codes.

Note: 60Hz. single phase motor CAN NOT be run on 50Hz. line without a physical change in the motor.

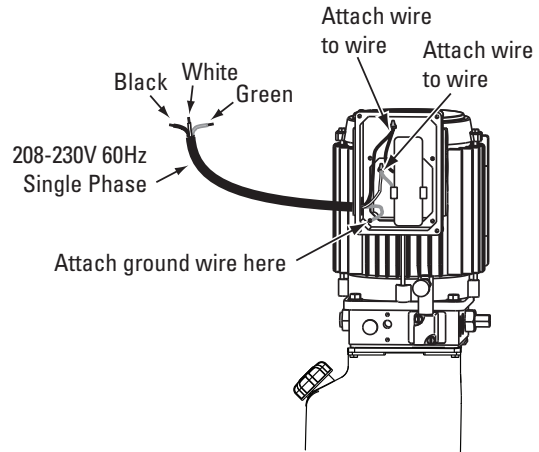

IMPORTANT Wiring Should Be Done By A Certified Electrician. Following All National, State, And Local Electrical Codes

Three Phase Wiring

NOTES:

- Unit not suitable for use in unusual conditions. Contact Rotary for moisture and dust environment duty unit.
- Control Box must be field mounted to power unit.
- Motor rotation is counter clockwise from top of motor.

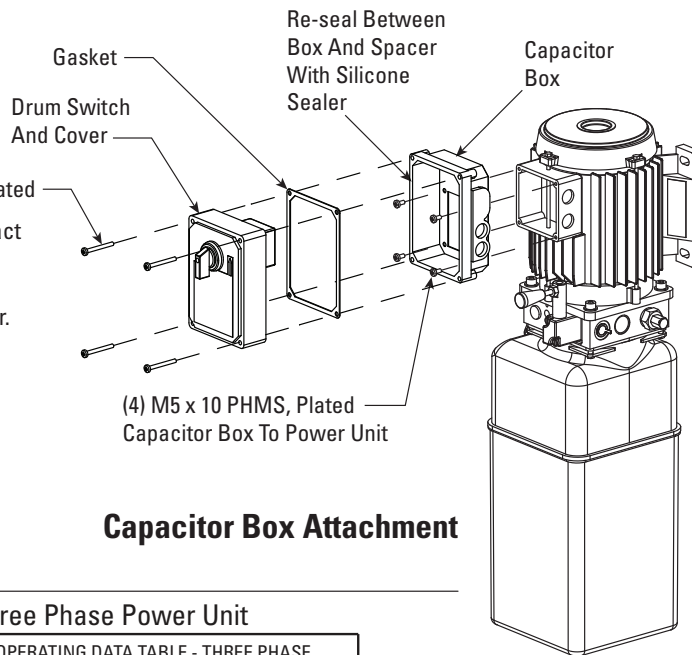
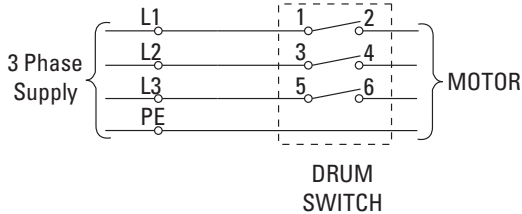

Three Phase Power Unit

MOTOR OPERATING DATA TABLE - THREE PHASE	
LINE VOLTAGE	RUNNING MOTOR VOLTAGE RANGE
208-240V 50/60Hz.	197-253V
400V 50Hz.	360-440V
440-480V 50/60Hz.	396V-528V
575V 60Hz.	518V-632V

Current Pin Layouts

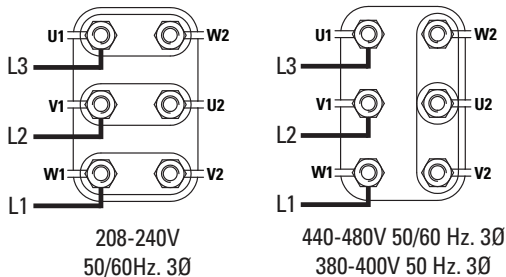

Older Pin Layouts

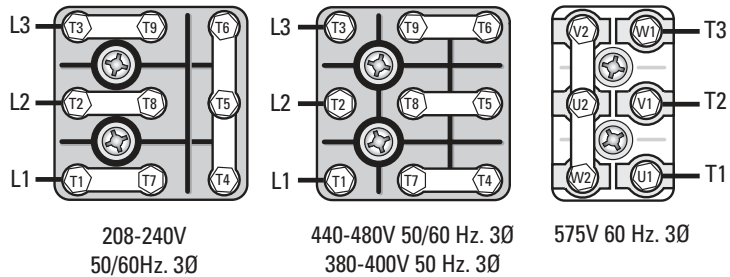

Step 13: Raising Lift For Final Assembly Steps:

A.) Press the raise button on power unit, Fig. 15, and raise the runways up to a comfortable working height, approximately waist high.

B.) Push down on the lowering valve to lower the runways onto locking latches.

IMPORTANT You have not yet completed the locking latch release linkage assembly at this point. Your lift will only lower onto the locking latches. Do not lift the runway too high until you complete step 13.

IMPORTANT Always have everyone in the area move away from the lift when it is in operation.

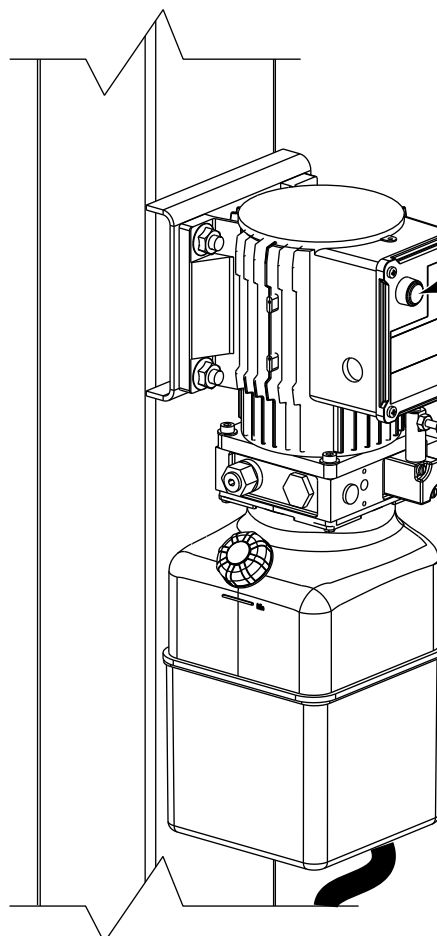

IMPORTANT Before Operating Lift, Read and Heed Instructions In Owner's Manual Along With All Safety, Caution, And Warning Labels.

ATTENTION!!! You CAN NOT Fully Lower Your Lift Until You Complete Step 13! Only Raise Runways To A Comfortable Working Height!

Fig. 15

Step 14: Inserting Latch Bar, Attaching Lock Cams And Latch Release Handle:

- A.) Remove outer crossbeam covers.
- B.) Insert latch bar through crossbeam assembly and through left side runway latch bar supports. Rod inserts from rear of lift and comes out near the power unit on the front of the lift.
- C.) Install Cam to Latch Release Bar as shown, Fig. 16.

- D.) Install Latch Release Handle to Cam as shown, Fig. 17.
- E.) Install Linkages to Cam as shown, Fig. 18. Cam should sit straight up and down when linkages are tight.
- F.) Repeat for linkages on approach end.
- G.) Re-attach outside crossbeam covers.

INSTALL CAM TO LATCH RELEASE ROD

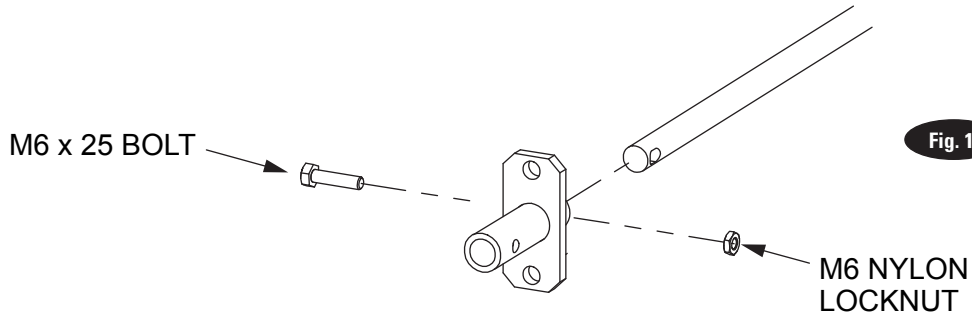

INSTALL HANDLE TO CAM

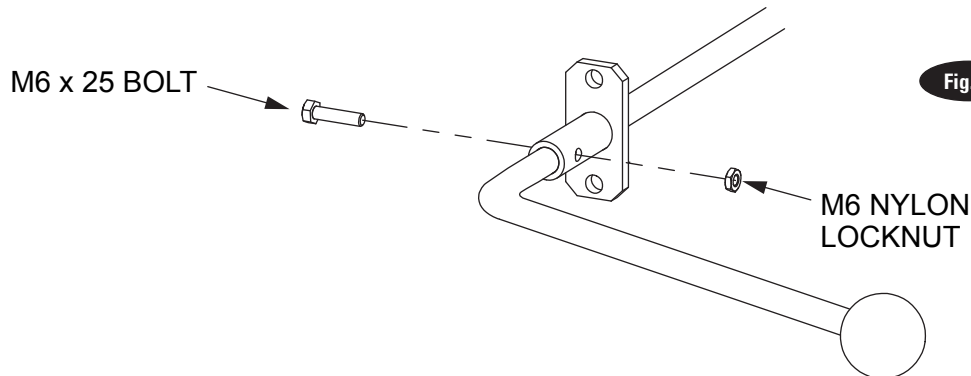

**INSTALL LINKAGES TO CAM
(ADJUSTMENT TO LINKAGES MAY BE NECESSARY)**

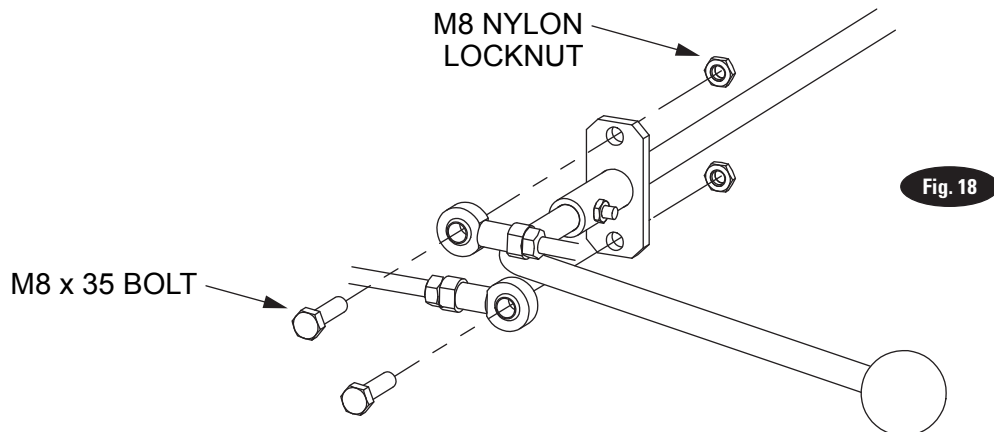

Step 15: Front Chock and Approach Ramp Installation:

A.) Attach front chock as shown, Fig. 19.

B.) Attach approach ramp with bar and cotter pins as shown, Fig. 20. Be sure to spread cotter pins after installation.

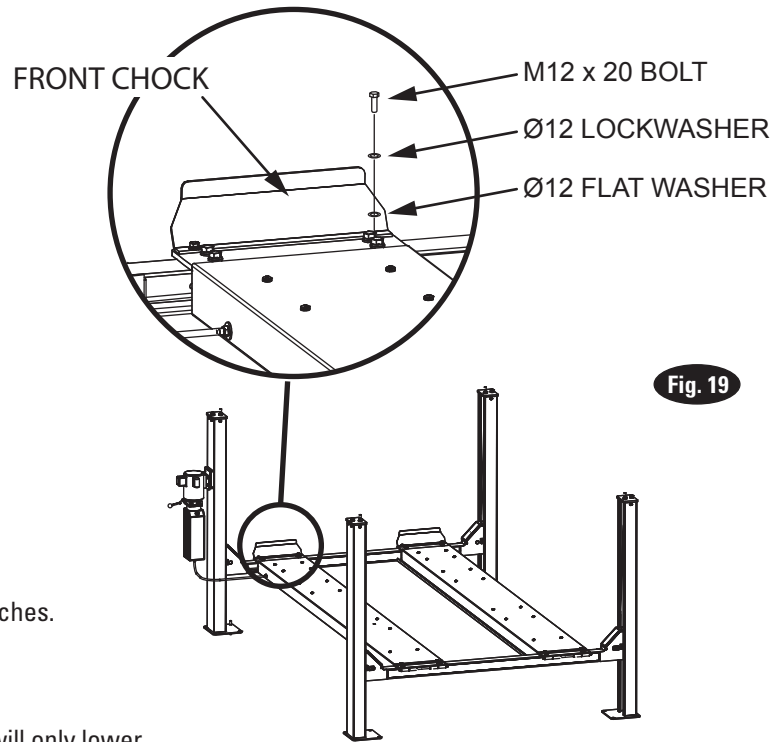

Step 16: Testing Your Lift:

- A.) Push button on power unit to raise your lift.
- B.) Pulling up on lock lever will release locking latches.
- C.) Push down on the lowering valve to lower lift.

Note: Without pulling up on the lock lever the lift will only lower onto the locking latches. Any time you lower the lift you will have to raise your lift off of the locking latches, (approximately 1 inch), and pull up on the lock lever to allow the locking latches to clear the slots in the latch bars. Releasing the lock lever will re-engage the locks. The lift will stop in the next locking position unless you are below the lowest slots in the latch bars. After you clear the lowest slots in the latch bars the lock lever may be released and the lift will completely lower the lift to the ground.

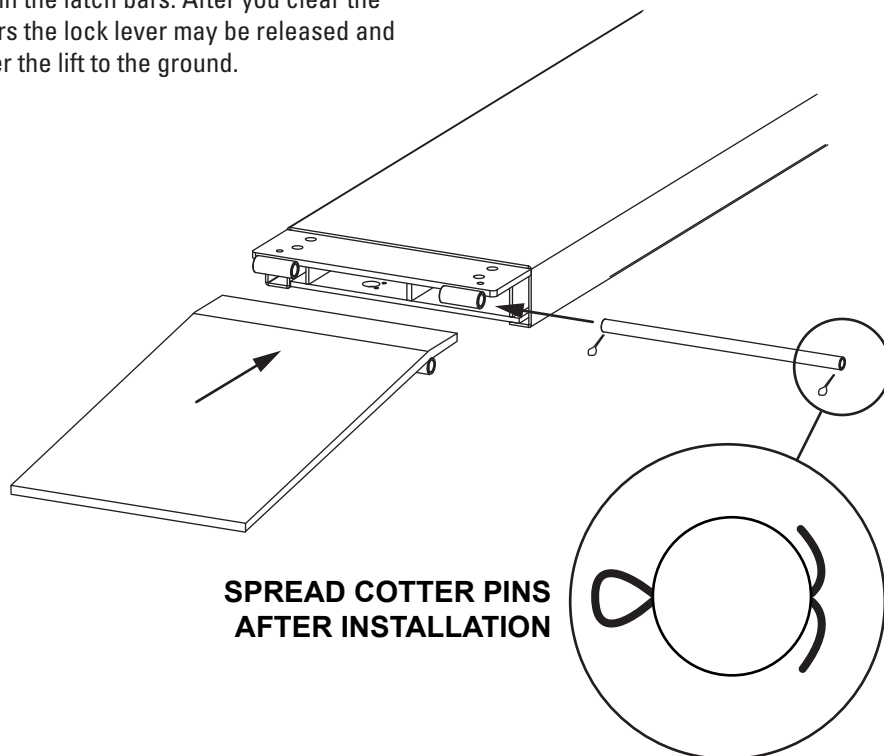

Step: 17: Leveling your lift:

- A.) Level the latch bars first. Make sure you have the lift off the ground and lowered onto the locking latches.
- B.) Start at the right front column and loosen jam nut and adjust your latch bar until there is 1/2 inch (13mm) of thread is exposed out of the top of the nut on top of the column, Fig. 21. Retighten jam nut.
- C.) Using a 4 ft. (2 yd.) level adjust the rest of the latch bars until runways are level. Exposed threads on the rest of the latch bars may vary depending how level the surface is where your lift is located.

- D.) Adjust your cables next starting at the left rear column. Lower the lift below the last slot in the latch bars so that the runways are only being supported by they cables.
- E.) Adjust the left rear cable to expose 1/4 inch (6mm) of the cable out of the top of the nut, Fig. 21.
- F.) Using the 4 ft. (2 yd.) level adjust the rest of the cables until runways are level. Exposed threads on cable studs may vary on the rest of the columns.

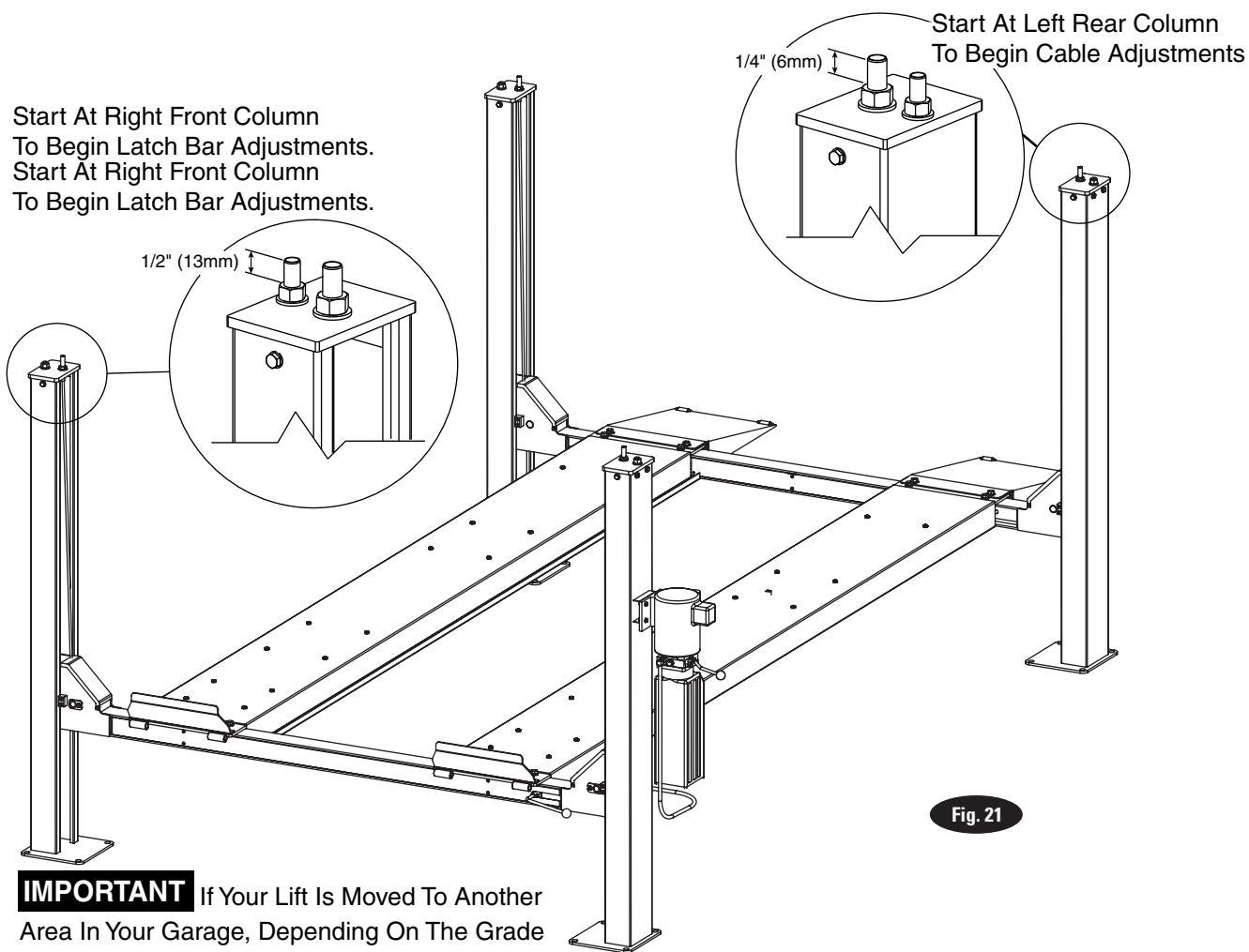

Fig. 21

IMPORTANT If Your Lift Is Moved To Another Area In Your Garage, Depending On The Grade Of The Floor, You May Need To Repeat Leveling Your Lift Instruction From Above

Notes

Notes

Notes



Forward Lift
996 Industrial Drive
Madison, IN. 47250

Phone: 800.445.5438
Fax: 800.578.5438
www.forwardlift.com

© 2011 Forward Lift; Forward Lift is a brand of Vehicle Service Group, A Dover Company. All rights reserved Unless otherwise indicated. Forward Lift, Vehicle Service Group, Dover, and all other trademarks are property of Dover Corporation and its affiliates.