

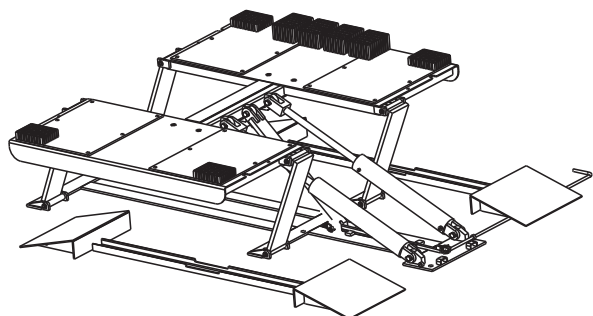

VLXS7
Low Rise Car Lift
 Capacity 7000 lbs.
 (Maximum 1750 lbs. per pad)



VLXS10
Low Rise Car Lift
 Capacity 10,000 lbs.
 (Maximum 2500 lbs. per pad)

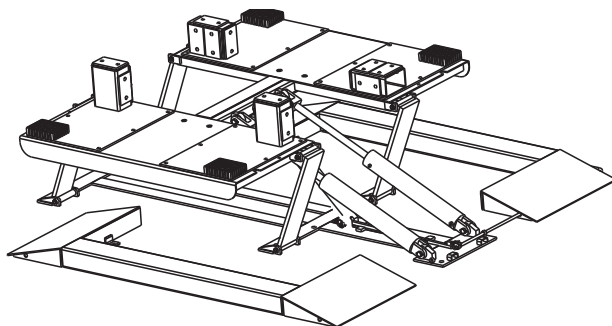

Table of Contents

SAFETY INSTRUCTIONS..... 2

OWNER/EMPLOYER RESPONSIBILITIES 3

OPERATING INSTRUCTIONS 4

MAINTENANCE INSTRUCTIONS 6

TROUBLE SHOOTING 7

SAFETY INSTRUCTIONS

- **Daily** inspect your lift. Never operate if it malfunctions or if it has broken or damaged parts. Use **only** qualified lift service personnel and genuine Rotary parts to make repairs.
- **Thoroughly** train all employees in use and care of lift, using manufacturer's instructions and "Lifting It Right" and "Safety Tips" supplied with the lift.
- **Never** allow unauthorized or untrained persons to position vehicle or operate lift.
- **Prohibit** unauthorized persons from being in shop area while lift is in use.
- **Do Not** permit anyone on lift or inside vehicle when it is either being raised or lowered.
- **Always** keep area around lift free of tools, debris, grease and oil.
- **Never** overload lift. Capacity of VLXS10 lift is 10,000 lbs., 2500 lbs. per pad. Capacity of VLXS7 lift is 7000 lbs., 1750 lbs. per pad.
- **Do Not** stand in front of the lift or vehicle while it is being positioned in lift bay.
- Before driving vehicle into lift bay, BE SURE lift is fully lowered.
- **Load** vehicle on lift carefully. Position lift adapters to contact at the vehicle manufacturer's recommended lift points. Raise lift until until adapters contact vehicle. Check adapters for secure contact with vehicle. Raise lift to desired working height.

CAUTION Do Not go under vehicle if locking latches are not engaged.

- **Do Not** block open or override self-closing lift controls; they are designed to return to the "Off" or Neutral position when released.
- **Remain clear** of lift when raising or lowering vehicle.
- **Always** lower lift completely and disconnect power source before disconnecting hydraulic lines.
- **Avoid** excessive rocking of vehicle while on lift.
- **Clear** area if vehicle is in danger of falling.
- **Completely** lower lift before removing vehicle from lift area.
- **Release** locking latches before attempting to lower lift.

IMPORTANT The locking leg latch will reset automatically **ONLY** when the lift is fully lowered. If during the lowering process the lift is stopped before it gets to the fully lowered position, the locking leg **MUST** be reset by manually rotating the latch release handle.

The Owner/Employer:

- Shall ensure that lift operators are qualified and that they are trained in the safe use and operation of the lift using the manufacturer's operating instructions; ALI/SM 93-1, *ALI Lifting it Right* safety manual; ALI/ST-90 *ALI Safety Tips* card; ANSI/ALI ALOIM-2000, *American National Standard for Automotive Lifts-Safety Requirements for Operation, Inspection and Maintenance*; ALI/WL Series, *ALI Uniform Warning Label Decals/Placards*; and in the case of frame engaging lifts, ALI/LP-GUIDE, *Vehicle Lifting Points/Quick Reference Guide for Frame Engaging Lifts*.
- Shall establish procedures to periodically inspect the lift in accordance with the lift manufacturer's instructions or ANSI/ALI ALOIM-2000, *American National Standard for Automotive Lifts-Safety Requirements for Operation, Inspection and Maintenance*; and The Employer Shall ensure that lift inspectors are qualified and that they are adequately trained in the inspection of the lift.
- Shall establish procedures to periodically maintain the lift in accordance with the lift manufacturer's instructions or ANSI/ALI ALOIM-2000, *American National Standard for Automotive Lifts-Safety Requirements for Operation, Inspection and Maintenance*; and The Employer Shall ensure that lift maintenance personnel are qualified and that they are adequately trained in the maintenance of the lift.
- Shall maintain the periodic inspection and maintenance records recommended by the manufacturer or ANSI/ALI ALOIM-2000, *American National Standard for Automotive Lifts-Safety Requirements for Operation, Inspection and Maintenance*.
- Shall display the lift manufacturer's operating instructions; ALI/SM 93-1, *ALI Lifting it Right* safety manual; ALI/ST-90 *ALI Safety Tips* card; ANSI/ALI ALOIM-2000, *American National Standard for Automotive Lifts-Safety Requirements for Operation, Inspection and Maintenance*; and in the case of frame engaging lifts, ALI/LP-GUIDE, *Vehicle Lifting Points/Quick Reference Guide for Frame Engaging Lifts*; in a conspicuous location in the lift area convenient to the operator.
- Shall provide necessary lockout/tagout means for energy sources per ANSI Z244.1-1982 (R1993), *Safety Requirements for the Lockout/Tagout of Energy Sources*, before beginning any lift repairs.
- Shall not modify the lift in any manner without the prior written consent of the manufacturer.

OPERATING INSTRUCTIONS

⚠️WARNING To avoid personal injury and/or property damage, permit only trained personnel to operate lift. After reviewing these instructions, get familiar with lift controls by running the lift through a few cycles before loading vehicle on lift.

IMPORTANT Always lift the vehicle using all four adapters. **NEVER** raise just one end, one corner, or one side of vehicle.

Observe and heed **SAFETY, CAUTION** and **WARNING** labels on the lift.

1. Lift must be fully lowered and service bay clear of all personnel before the vehicle is brought on lift.

2. Spot vehicle over lift with left front wheel in proper spotting dish position, Fig. 1. Be sure vehicle wheels and/or mud flaps clear pad end ramps.

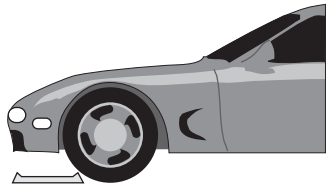

Less than 105" (2667mm) wheelbase:
position left front wheel on approach side of wheel dish.

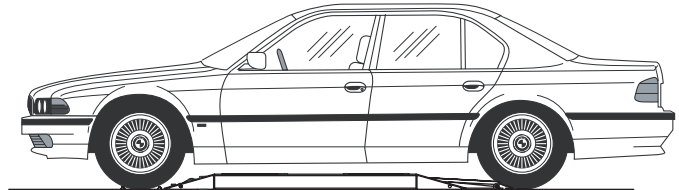

Vehicle Spotting Position

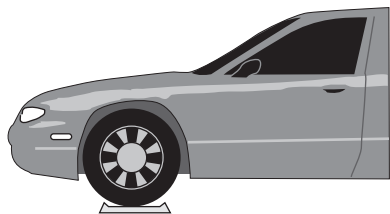

105"-127" (2667mm - 3226mm) wheelbase:
position left front wheel in wheel dish.

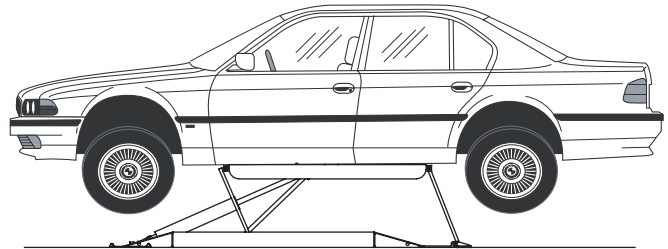

Vehicle Loading Position

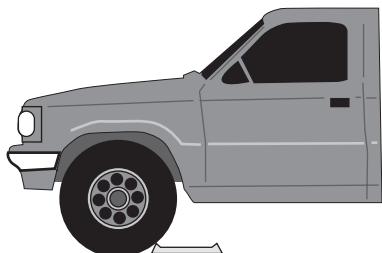

Larger than 127" (3226mm) wheelbase:
position left front wheel just forward of wheel dish.

⚠️WARNING Most specialty or modified vehicles cannot be raised on a frame engaging lift. Contact vehicle manufacturer for raising or jacking details.

Fig. 1

Typical Lifting Points

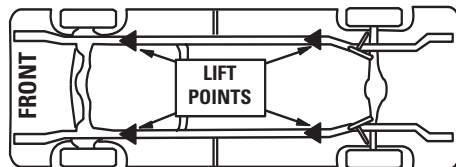

Pickup Truck

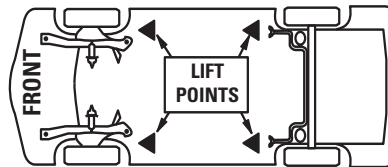

Unitized Body

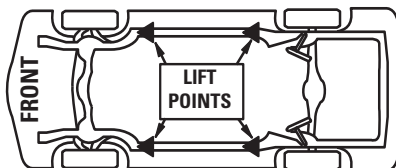

Perimeter Frame

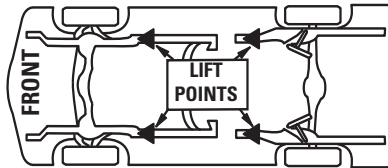

Stub Frame

NOTE: Some vehicles may have the manufacturer's Service Garage Lift Point locations identified by triangle shape marks on it's undercarriage (reference ANSI/SAE J2184-1992). Also, there may be a label located on the right front door lock face showing specific vehicle lift points. If the specific vehicle lift points are not identified, refer to the "Typical Lift Points" illustrated herein. ALWAYS follow the operating instructions supplied with the lift.

3. **Loading:** **IMPORTANT** Vehicle manufacturer's recommended pick up points **MUST** be able to be engaged by lift structure or adapter blocks. Vehicle frame **MUST** be strong enough to support it's weight and has not been weakened by modification or corrosion. **DO NOT** raise limousines, specialty, or other modified vehicles.

*Maximum operation pressure is:
1050 psi for VLXS7
1050 psi for VLXS10

Before lifting vehicle be sure that:

- A. Pads are in secure contact with frame or support structure at vehicle manufacturer's recommended pick up points.
B. Certain vehicles such as Camaro, Firebird, Escort, or Chrysler "K" Cars or others may require additional clearance under carriage or exhaust system from contacting pad support. Use auxillary adapters. Locate at vehicle manufacturer's recommended pick up points.

Note: Allow (2) seconds between motor starts. Failure to comply may cause motor burnout.

4. **To Raise Lift:**

- A. Push Raise Switch (A) on power unit, Fig. 2.
B. Stop before making contact with vehicle. Be sure wheels and/or mud flaps clear pad end ramps.
C. Raise vehicle until tires clear the floor.
D. Stop and check pads for secure contact at vehicle manufacturer's recommended lift points.
E. Continue to raise to desired height only if vehicle is secure on lift.
F. Repeat complete spotting, loading and raising procedures if required.
H. Actuate Lowering Handle (B), Fig. 2, to lower lift onto locking latches.

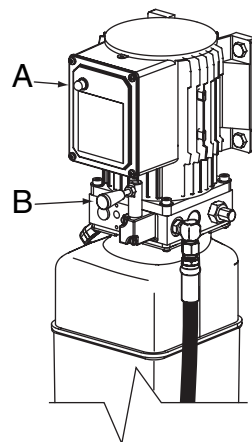

**A. Raise Switch
B. Lowering Valve Handle**

Fig. 2

CAUTION DO NOT go under vehicle if locking latches are not engaged.

5. **While Using Lift:**

- A. Avoid excessive rocking of vehicle while on lift.

6. **To Lower Lift:**

- A. Remove all tools, bystanders, and other objects from lift area.
B. Raise lift off locking latches.
C. Rotate Latch Release Handle, Fig. 3.
D. Push Lowering Valve Handle (B) to lower lift, Fig. 2.

Note: The Lowering Valve Handles are deadman-type design. Each must be held down to lower lift.

CAUTION DO NOT override self-closing lift controls.

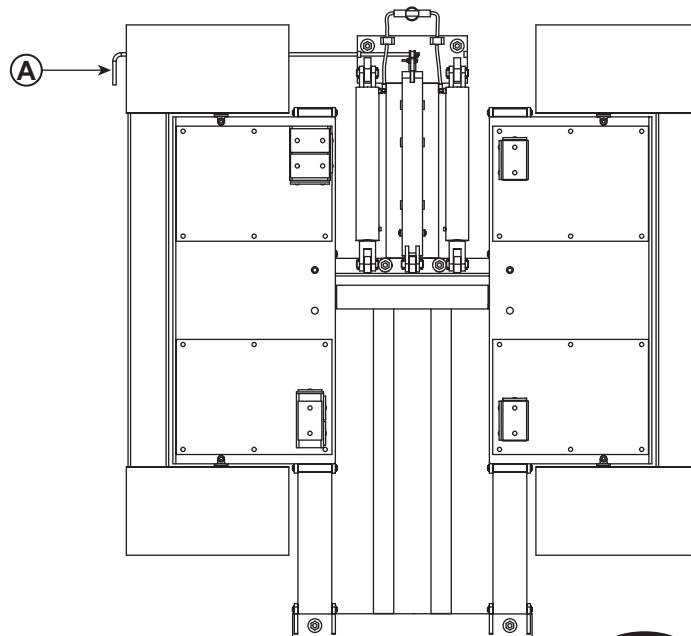

A. Latch Release Handle

Fig. 3

7. Remain clear of lift when lowering vehicle.
8. Remove adapters from under vehicle. Be sure lift is fully lowered before removing vehicle.
9. If lift is not operating properly, **Do Not** use until adjustment or repairs are made by qualified lift service personnel.

MAINTENANCE INSTRUCTIONS

⚠ WARNING If you are not completely familiar with automotive lift maintenance procedures **STOP**: Contact factory for instructions.

To Avoid Personal Injury, permit only qualified lift service personnel to perform maintenance on this equipment.







Use only genuine Rotary replacement parts for repairs.

- **Always** keep all bolts tight. Check periodically.
- **Always** raise lift when cleaning floor area.
- **Always** keep lift clean.
- **Daily**: Inspect adapters for damage or excessive wear. Replace as required with genuine Rotary parts.
- **Daily**: Check latch release handle on lift for damage or binding.
- **Weekly**: Inspect all lift parts for signs of damage due to overloading and rough handling.
- **Monthly**: Lubricate cylinder/locking leg bolt and locking leg release handle pivot.
- **Monthly**: Lubricate hinge joints if excessive rusting occurs.
- **Semi-Annually**: Check fluid level of lift power unit. With lift fully lowered, fluid should be at MIN ___ mark on tank. Refill if required per lift installation instructions. If fluid is required, inspect all hoses and seals. Repair as required.
- **Every 3 Months**: Check anchor bolts for tightness. Anchors should be torqued to 65 ft. lbs. (85Nm).
- **If lift stops** short of full rise or chatters, check fluid level and bleed both cylinders per lift installation instructions.
- **Replace** all CAUTION, WARNING, or SAFETY related decals on the lift if unable to read or missing. Reorder labels from Rotary Lift.

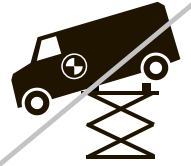
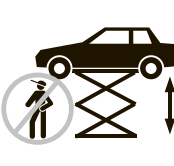
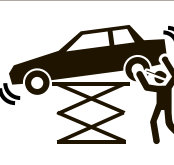
SAFETY WARNING LABELS FOR HINGED FRAME ENGAGING LIFTS

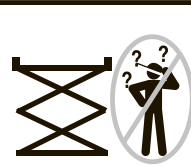
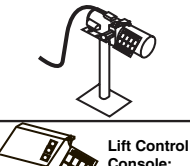
Lift Owner/User Responsibilities:

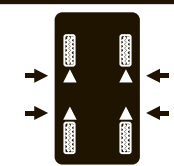
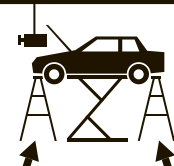
- A. This Safety Warning placard **SHALL** be displayed in a conspicuous location in the lift area.
- B. Use one of the mounting arrangements illustrated on back of this placard.
- C. These Safety Warning labels supplement other documents supplied with the lift.
- D. Be certain all lift operators read and understand these labels, operating instructions and other safety related information supplied with the lift.

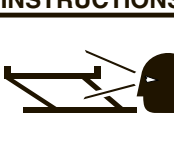
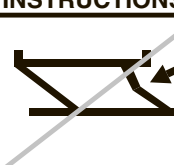
<p>⚠ WARNING</p>  <p>Position vehicle with center of gravity midway between adapters. ©</p>	<p>⚠ WARNING</p>  <p>Remain clear of lift when raising or lowering vehicle. ©</p>	<p>⚠ WARNING</p>  <p>Keep feet clear of lift while lowering. ©</p>
<p>⚠ WARNING</p>  <p>Clear area if vehicle is in danger of falling. ©</p>	<p>⚠ WARNING</p>  <p>Avoid excessive rocking of vehicle while on lift. ©</p>	<p>⚠ WARNING</p>  <p>Keep clear of pinch points when lift is moving. ©</p>
<p>⚠ CAUTION</p>  <p>Lift to be used by trained operator only. ©</p>	<p>Power Unit: Secure placard near lift controls.</p>  <p>Lift Control Console: Secure placard in an accessible location.</p> <p>The messages and pictographs shown are generic in nature and are meant to generally represent hazards common to all automotive lifts regardless of specific style.</p> <p>Funding for the development and validation of these labels was provided by the Automotive Lift Institute, PO Box 1519 New York, NY, 10101-1519.</p> <p>They are protected by copyright. Set of labels may be obtained from ALI or its member companies.</p> <p>© 1992 by ALI, Inc. ALI/WL300csw</p>	
<p>⚠ CAUTION</p>  <p>Authorized personnel only in lift area. ©</p>	<p>⚠ CAUTION</p>  <p>Use vehicle manufacturer's lift points. ©</p>	<p>⚠ CAUTION</p>  <p>Always use safety stands when removing or installing heavy components. ©</p>
<p>SAFETY INSTRUCTIONS</p>  <p>Read operating and safety manuals before using lift. ©</p>	<p>SAFETY INSTRUCTIONS</p>  <p>Proper maintenance and inspection is necessary for safe operation. ©</p>	<p>SAFETY INSTRUCTIONS</p>  <p>Do not operate a damaged lift. ©</p>

TROUBLE SHOOTING

Trouble	Cause	Remedy
Electric motor does not run.	<ol style="list-style-type: none"> 1. Check fuse or circuit breaker. 2. Check for correct voltage to motor. 3. Inspect all wiring connections. 4. Microswitch burned out. 5. Motor windings burned out. 	<ol style="list-style-type: none"> 1. Replace blown fuse or reset circuit breaker. 2. Supply correct voltage to motor. 3. Repair and insulate all connections. 4. Replace microswitch. 5. Replace motor.
Electric motor runs but will not raise lift.	<ol style="list-style-type: none"> 1. Motor runs in reverse rotation. 2. Open lowering valve. 3. Pump sucking air. 4. Suction stub off pump. 5. Low fluid level. 	<ol style="list-style-type: none"> 1. Change motor rotation by reversing motor leads. 2. Repair or replace lowering valve. 3. Tighten all suction line fittings. 4. Replace suction stub. 5. Fill tank with Dexron III ATF or ISO 32 hydraulic fluid.
Electric motor runs—raises unloaded lift but will not raise vehicle.	<ol style="list-style-type: none"> 1. Motor running on low voltage. 2. Trash in lowering valve. 3. Overloading lift. 4. Improper relief valve adjustment. 	<ol style="list-style-type: none"> 1. Supply correct voltage to motor. 2. Clean lowering valve. 3. Check vehicle weight and/or balance vehicle weight on lifts. 4. Replace relief valve cartridge.
Lift slowly settles down.	<ol style="list-style-type: none"> 1. Trash in check valve seat. 2. Trash in lowering valve seat. 3. External fluid leaks. 	<ol style="list-style-type: none"> 1. Clean check valve. 2. Clean lowering valve. 3. Repair external leaks.
Slow lifting speed or fluid blowing out fill/breather cap.	<ol style="list-style-type: none"> 1. Air mixed with fluid. 2. Air mixed with fluid suction. 3. Fluid return tube loose. 	<ol style="list-style-type: none"> 1. Change fluid to Dexron III ATF or ISO 32 hydraulic fluid. 2. Tighten all suction line fittings. 3. Reinstall fluid return tube.
Lift going up unlevel.	<ol style="list-style-type: none"> 1. Lift installed on unlevel floor. 	<ol style="list-style-type: none"> 1. Shim lift to level base, refer to page 2, step 3 in Installation Instruction.
Anchors will not stay tight.	<ol style="list-style-type: none"> 1. Concrete floor thickness or holding strength not sufficient. 	<ol style="list-style-type: none"> 1. Break out old concrete and repour new pad for lift.
Lift will not raise off of latches.	<ol style="list-style-type: none"> 1. Motor, pump, or cylinder failure. 	<ol style="list-style-type: none"> 1. Contact lift manufacturer's Customer Service.

LIFT LOCKOUT/TAGOUT PROCEDURE

Purpose

This procedure establishes the minimum requirements for the lockout of energy that could cause injury to personnel by the operation of lifts in need of repair or being serviced. All employees shall comply with this procedure.

Responsibility

The responsibility for assuring that this procedure is followed is binding upon all employees and service personnel from outside service companies (i.e., Authorized Rotary Installers, contactors, etc.). All employees shall be instructed in the safety significance of the lockout procedure by the facility owner/manager. Each new or transferred employee along with visiting outside service personnel shall be instructed by the owner/manager (or assigned designee) in the purpose and use of the lockout procedure.

Preparation

Employees authorized to perform lockout shall ensure that the appropriate energy isolating device (i.e., circuit breaker, fuse, disconnect, etc.) is identified for the lift being locked out. Other such devices for other equipment may be located in close proximity of the appropriate energy isolating device. If the identity of the device is in question, see the shop supervisor for resolution. Assure that proper authorization is received prior to performing the lockout procedure.

Sequence of Lockout Procedure

- 1) Notify all affected employees that a lockout is being performed and the reason for it.
- 2) Unload the subject lift. Shut it down and assure the disconnect switch is "OFF" if one is provided on the lift.
- 3) The authorized lockout person operates the main energy isolation device removing power to the subject lift.
 - If this is a lockable device, the authorized lockout person places the assigned padlock on the device to prevent its unintentional reactivation. An appropriate tag is applied stating the person's name, at least 3" x 6" in size, an easily noticeable color, and states not to operate device or remove tag.
 - If this device is a non-lockable circuit breaker or fuse, replace with a "dummy" device and tag it appropriately as mentioned above.
- 4) Attempt to operate lift to assure the lockout is working. Be sure to return any switches to the "OFF" position.
- 5) The equipment is now locked out and ready for the required maintenance or service.

Restoring Equipment to Service

- 1) Assure the work on the lift is complete and the area is clear of tools, vehicles, and personnel.
- 2) At this point, the authorized person can remove the lock (or dummy circuit breaker or fuse) & tag and activate the energy isolating device so that the lift may again be placed into operation.

Rules for Using Lockout Procedure

Use the Lockout Procedure whenever the lift is being repaired or serviced, waiting for repair when current operation could cause possible injury to personnel, or for any other situation when unintentional operation could injure personnel. No attempt shall be made to operate the lift when the energy isolating device is locked out.

OPERATING CONDITIONS

Lift is not intended for outdoor use and has an operating ambient temperature range of 41°-104°F (5°-40°C).

Certificate of Compliance

Rotary Lift is authorized to apply ETL & cETL Listing Marks/Labels to this AC Motor. Authorization: ETL Report No. J98007541-003, FAM -UL73. This ETL test certifies that this AC Motor complies with Underwriters Laboratories, Inc. standard ANSI/UL 73, 8th Edition & CSA standard C22.2 No. 68-92.



SV0021 A Rev. 6/9/99

Trained Operators and Regular Maintenance Ensures Satisfactory Performance of Your Rotary Lift.

Replacement Parts: See installers package for parts breakdown sheet. Order Genuine Rotary replacement parts from your nearest Authorized Parts Distributor.

Maintenance Assistance: Contact your local Rotary distributor.

Should further assistance be required, contact Rotary Lift, at one of the phone numbers listed below.

Rotary World Headquarters

2700 Lanier Drive
Madison, IN 47250, USA
www.rotarylif.com

North America Contact Information

Tech. Support:
p 800.445.5438
f 800.578.5438
e userlink@rotarylif.com
Sales:
p 800.640.5438
f 800.578.5438
e userlink@rotarylif.com

World Wide Contact Information

World Headquarters/USA: 1.812.273.1622
Canada: 1.905.812.9920
European Headquarters/Germany: +49.771.9233.0
United Kingdom: +44.178.747.7711
Australasia: +60.3.7660.0285
Latin America / Caribbean: +54.3488.431.608
Middle East / Northern Africa: +49.771.9233.0

© Vehicle Service GroupSM

Printed in U.S.A., All Rights Reserved. Unless otherwise indicated, ROTARY, and all other trademarks are property of Dover Corporation and its affiliates.

