

Owners Manual

DS7000I

Recess Mounted Version

Capacity 7000 lbs. (3175 Kg)

Maximum 3500 lbs. (1587 Kg) per pad

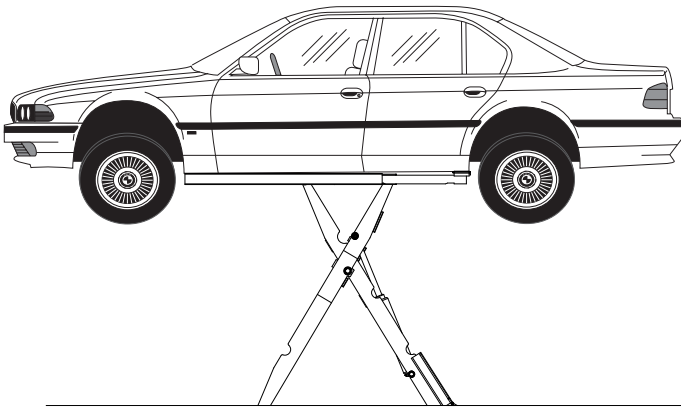

DS7000N

Surface Mounted Version

Capacity 7000 lbs. (3175 Kg)

Maximum 3500 lbs. (1587 Kg) per pad

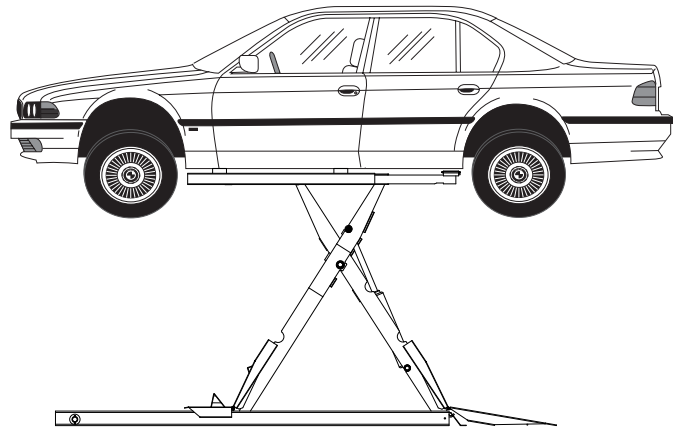

Table of Contents

INTRODUCTION-PACKING-TRANSPORT	2
MACHINE DESCRIPTION.....	3
SAFETY INSTRUCTIONS.....	5
OPERATION.....	6
MAINTENANCE INSTRUCTIONS	6
TROUBLE SHOOTING	10
ACCESSORIES	12
SPARE PARTS.....	12
MAINTENANCE BOOK.....	13

IMPORTANT NOT INTENDED TO BE USED WITH FRAME VEHICLES, SUCH AS FULL SIZE PICKUP TRUCKS

LP50031

INTRODUCTION

- This manual was written for shop technicians (car lift operators) and maintenance technicians. Before operating these lifts, please read these instructions completely. The lift should be operated only by purposely trained technicians over 18 years of age, in full observance of the regulations in the country where the lift is installed. This manual covers important information for:

- **Safety of people;**
- **Safety of the car lift;**
- **Safety of lifted car.**

- This manual is considered to be a permanent part of the lift and must be kept in an easily accessible place so that the operator can find it and refer to it any time. **PARTICULARLY CAREFUL READING SAFETY INSTRUCTIONS IS RECOMMENDED.**

⚠ WARNING Only skilled and previously authorized technicians should be allowed to carry out transport, assembling, setting, maintenance, overhaul, moving, dismantling operations, etc. concerning the lift.

- The manufacturer is not responsible for possible damage to people, vehicles and objects, caused by improper use of the lift.
- Read this instruction completely before operating the lift.
- Always start the hydraulic and electric system before the pneumatic connection from the lift to the control box is carried out.
- The lift must be only used for vehicles up to the specified capacity. Any improper use of this lift is strictly forbidden.
- Disconnect the lift from the main electric supply before any extraordinary maintenance operation.

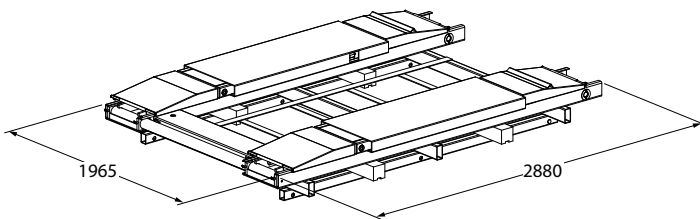

Fig. 1

- Lift installation must be carried out as specified by these instructions.
- Service test; proceed as described on page 15.

NOTE: The manufacturer is not liable for possible damage resulting from failure to follow the instruction supplied with this car lift.

PACKING/TRANSPORT

Standard versions of the car lift are pre-assembled and equipped as follows (Fig 1 and Fig 2):

- 2 x bases and platforms (p1-p2) placed on top of each other, with pallet and wooden shims, and sealed with "pluriball" and metal clamps.
- 1 x control box sealed with "pluriball" and metal clamps and wooden shims (packed on the lift).
- 1 x cardboard box equipped with electric and hydraulic connections, rubber pads (packed on the lift).
- Packing can be lifted or moved by fork lift trucks, cranes or bridge cranes. In case of slinging, a second person must always take care of the load to avoid dangerous oscillations.
- At the arrival of goods, check for possible damage due to transport operations. Also verify that all items specified in the delivery notes are included. In case of damage or possible defects in transit, the person in charge or the carrier must be immediately informed. Furthermore, during loading and unloading goods must be handled using slinging, and wooden spacers to prevent carton box from damaging.

PACKING REMOVAL

- Wooden packing and pluriball packing can be recycled, in case of total packing removal, comply with the rules in force in the lift installation country.

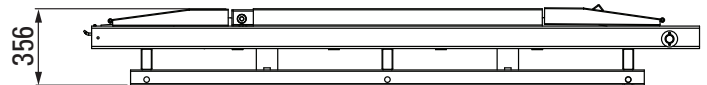

Fig. 2

MACHINE DESCRIPTION

DS7000 models are single-scissor and fixed (that is anchored to the ground) car lifts. They have been designed and built for vehicle lifting and placing operations.

Our car lifts are equipped as follows (Fig 3):

- **A-BASE** (Fixed structure)
- **B-BOOMS, PLATFORM** (Lifting and travelling structure).
- **C-CONTROL BOX**

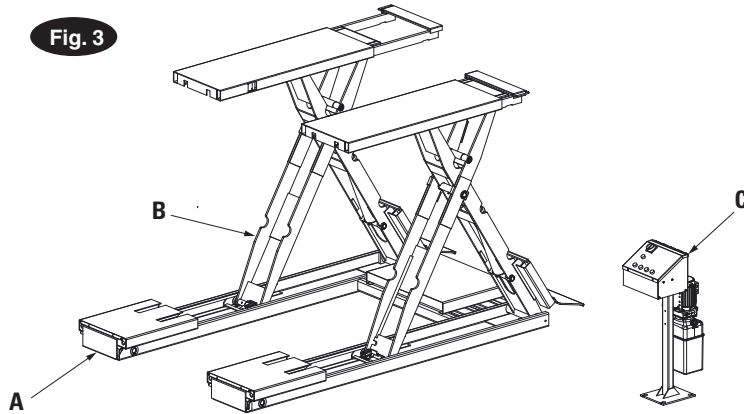

Fig. 3

FIXED STRUCTURE UNIT.

This is the car lift base, made of a structural steel sheet with floor fixing holes.

LIFTING AND TRAVELING STRUCTURE UNIT.

This is composed of steel booms and a platform. The platform is made of structural steel sheet with supporting uprights that are anchored to the booms by steel pins at the fixed points, and by sliders at the movable ones.

CONTROL BOX.

The unit is made of a metallic box containing oil tank, pump-motor assembly, electro-valve assembly and electrical and hydraulic supply connections. Low-voltage controls (24V) are placed on the power unit. they are the following (Fig 4):

1. **Lifting push button:** When pressed, motor and lifting mechanism are operated.
2. **Lowering push button:** When pressed, lowering electro valves are operated and locks are open. Lowers to toe guard position.
3. **Lower to lock button:** When pressed, lowering electro valves are operated to lower lift to nearest lock position.
4. **Full Lower:** Must be pressed along with the lowering button once the lift reaches the toe guard position. This will then lower the lift completely to the ground. Buzzer is activated during the lowering.

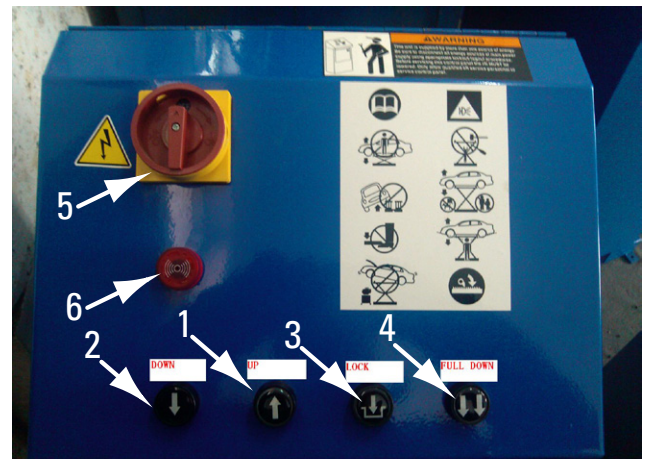

Fig. 4

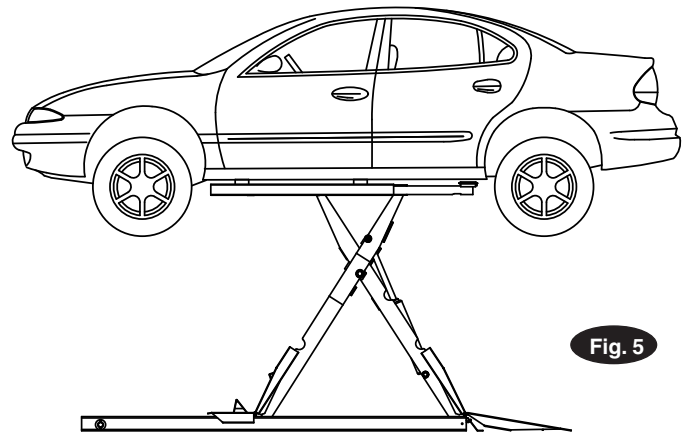

Fig. 5

5. **Master/Emergency switch:** if rotated, power supply to the control unit is cut off. Rotate clockwise (see the arrows) to restart.
6. **Buzzer:** it is activated during final lowering below the toe guard position.

NOTE: DS7000 single scissor car lifts are able to lift vehicles and vans whose weight is no more than 7000lbs (3175kg). All version are equipped with extension platforms so vehicles with a longer "wheel

SAFETY INSTRUCTIONS

GENERAL RULES

- Read this chapter carefully it contains important information concerning the safety of the operator. The operator and the maintenance personnel are required to observe the accident prevention legislation in force in the country of installation of the lift.

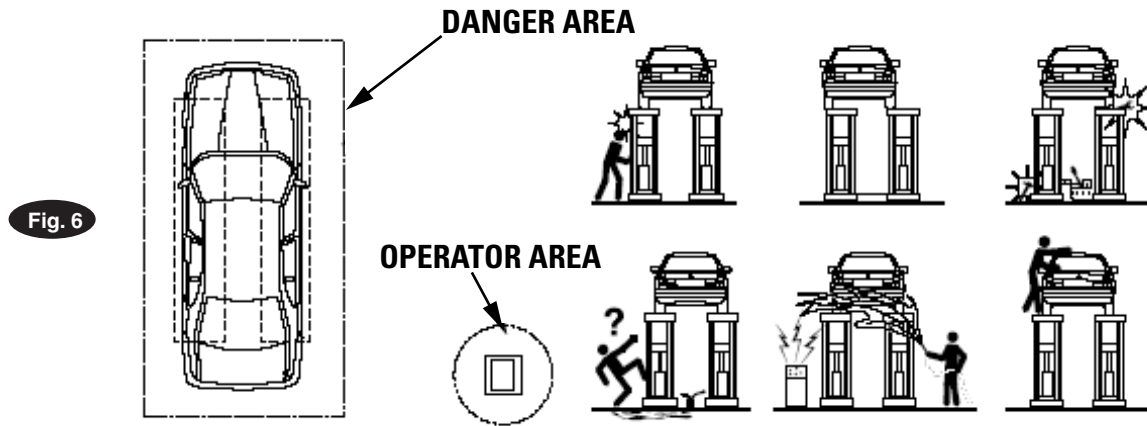

⚠ WARNING

1. During lifting or lowering operations, the lift must be operated only from the operator area as shown in the diagram (Fig. 6).
2. Standing or passing within the danger area when the lift is working or the vehicle is raised is strictly forbidden.
3. The operator must make sure the hazard area is clear when lifting or lowering the lift
4. Never use the lift without protection or when safety devices are off-line.
5. Always use the rubber pads when lifting a vehicle, observing the proper points of support specified by the vehicle's manufacturer.
6. Switch off the engine and engage the parking brake after placing the vehicle on the car lift; Furthermore, disengage the shift lever and move it to the "neutral position.
7. To prevent the vehicle from falling make sure it is properly placed on the lift.
8. Getting in or on the vehicle and-or starting the engine when the car lift is raised is strictly forbidden.
9. Never leave objects and-or obstructions under the vehicle or scattered on it during the lowering phase.
10. Keep the area under/next to the lift clear and remove possible oil spots to avoid the risk of slipping.
11. Never use water-steam-varnish-solvent jets in the lift area, and particularly, close to the control box.
12. Proper lighting is extremely important. Make sure all areas next to the car lift are well and uniformly lit, according to that specified by the applicable laws of the place of installation.
13. Climbing on the platform when lifting the vehicle or when the same has been already raised is strictly forbidden.
14. Any use of the lift other than what herein specified can cause serious accidents to the operator as well as to the people in close proximity.
15. The tampering of safety devices is strictly forbidden.
16. Never exceed the maximum lifting capacity. Make sure the vehicles to be raised are without loads.
17. In case of anomaly, stop the car lift and block the on/off selector by using a padlock. Only skilled technicians should be allowed to restart the lift. Be sure the power supply is off before repairing and servicing the lift. The operator, the lift or the vehicles raised can be seriously damaged if these instructions are not followed.

SAFETY DEVICES

- **ANTI-SHEARING SAFETY:** The lift is equipped with a device that stops its lowering phase at 1,2dm from the floor. To restart and close the lift, release the lowering button (2) (Fig. 4), and repress the lowering button along with the full lower button. During the lowering phase, the device will produce a warning acoustic signal (beep).
- **SAFETY VALVE FOR AUTOMATIC LOWERING CUT OUT:** Parachute valves able to automatically lock a single or double-acting cylinder in case a sudden increase in velocity occurs. The valves are located inside the cylinders and prevent the load from falling down in case of sudden pipe bursting or cutting.
- **DEAD-MAN CONTROL:** The car lift is equipped with a dead man control. Lowering and lifting operations are stopped immediately by releasing push button controls.
- **MASTER SWITCH:** The master switch (4) (Fig. 4). It deactivates all functions. Padlock the switch to prevent unauthorized personnel from using the lift.
- **EMERGENCY STOP:** By rotating the master switch button (6) (Fig. 4), power supply to the lift is cut off and all functions are disconnected.
- **MECHANICAL LOCKS:** The platforms and vehicle load is supported by locks. The platforms lower to locks in case of hydraulic or equalizer failure.

CHAPTER 6 - OPERATION

- **Driving Sequence:** Be sure the platforms are fully closed before getting on/off the lift. **Get in the vehicle and drive on the lift; be sure the vehicle is centered and both rear and front wheels are properly positioned, place the proper rubber pads on the platform (Fig. 7) so that they are in line with the lifting points specified by the manufacturer.** Press the "lifting" button, keep it pressed until the required height is reached. To lower the lift, press the "lowering" button (Fig. 4, pos.2). During the latest lowering phase with the full lower button "lowering in the dangerous area" the lift will produce a safety acoustic signal. **During the first hours of operation cracking noises could occur. This is due to the natural settlement of mechanical parts and will disappear during the following hours of operation.**

CHECKS

- Perform the following checks when operating the car lift:
- Carefully check the car lift and its load during lifting/lowering operation.
 - Check the warning acoustic signal operation of the car lift during lowering phase.
 - **ATTENTION:** When the lift is operating, there is high pressure in the hydraulic pipes (180 bar max).

CHAPTER 6 - MAINTENANCE

WARNING! Only skilled and previously authorized personnel should be allowed to service the lift. When servicing the lift, all safety precautions must be followed to avoid accidental starting of the machine. The master switch must be padlocked in "zero" position. The key should be kept by the maintenance technician throughout the service. During service operations, all safety instructions reported in chapter, "SAFETY", must always be followed.

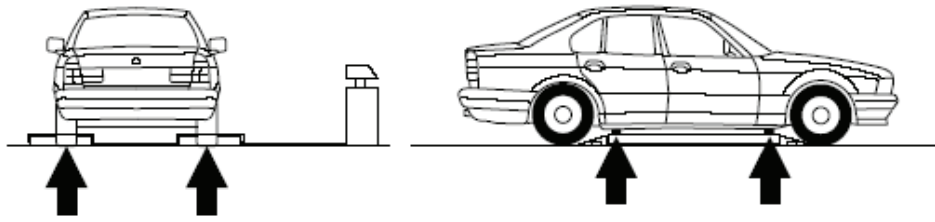

Fig. 7

PERIODIC MAINTENANCE

Maintenance operations must be performed at each specified maintenance period in order to keep the car lift in perfect working condition. The manufacturer is not liable for possible damage resulting from failure to follow the above instructions.

- Car lift must be cleaned once a month, at least, without using chemical agents and height pressure washing guns. **Always dispose of used brake oil to prevent possible damage to the finish. Carefully check that piston rods are not damage since inside gaskets and seals could be seriously damaged and leakage of oil occur.**
- Check safety devices for proper working condition periodically.
- Grease slide ways periodically.
- Check flexible tubes for proper conditions yearly.
- Change oil in the hydraulic system at 5 year intervals, at least. Used oil drained from the system during oil change operations should be treated as a highly pollutant product. Always dispose of used oil as specified by the law in force in the country where the car lift is installed.

MACHINE DEMOLITION

When demolishing the machine all safety precautions specified in chapter "3"- "4" must be followed. Only authorized technicians should be allowed to perform this operation. Metallic parts can be scrapped as "scrap iron". In any case, demolished material must be eliminated according to the effective laws of the country where the car lift is installed. It must be remembered that, for fiscal purposes, any demolition operation must be properly documented as specified by the effective laws of the country where the lift is installed at the time of demolition.

MANUAL LOWERING

IMPORTANT Make sure nothing is under the lifting structure of the vehicle and all unauthorized personnel are away from the lift area.

1. Review instructions before using the MANUAL LOWERING KIT (MLK).
2. Remove fill plug from MLK, Fig. 8.
3. Fill with Dexron III ATF or ISOVG32 Hydraulic Oil. Replace plug once full.
4. Remove cap from end of hose on MLK, Fig. 8.
5. Rotate the MLK Valve clockwise to open, Fig. 8.
6. SLOWLY hand pump MLK until fluid begins to flow from the end of the hose.
7. Push button on lift power unit lowering valve, Fig. 1. This will release the existing pressure in the lift system.
8. Remove and save plug from power unit valve port, Fig. 1. Attach and hand tighten half coupling provided with MLK to valve port.
9. Using wrench tighten 1/2 turn after o-ring makes contact with valve body.
10. Attach 1/2 coupling on MLK hose with 1/2 coupling just installed in valve body.
11. Pump handle on MLK approximately 100-200 times to raise lift until the latches can be released.
12. Push button on lowering valve and push button on the bottom of the air valve to completely lower lift. Observe all pinch point warnings.
13. After vehicle is fully lowered turn MLK valve counter- clockwise.
14. Press and hold the button on the lowering valve to allow the fluid to drain back into the MLK reservoir.
15. Disconnect the (2) 1/2 couplings on the end of MLK hose. Remove coupling from valve body and replace plug. Using wrench tighten 1/2 turn after o-ring makes contact with valve body. Place 1/2 coupling back on end of hose for future use.

If your facility lost power your lift will operate when you regain power. If facility power was not lost, have a certified electrician check wiring to lift.

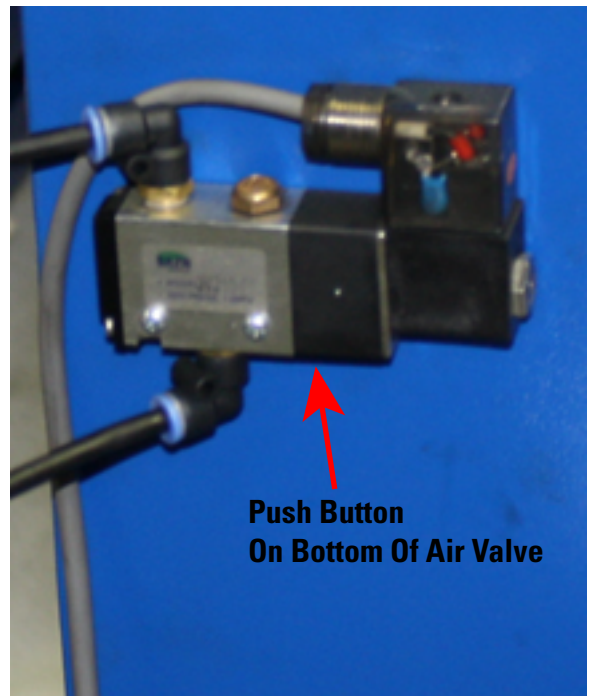
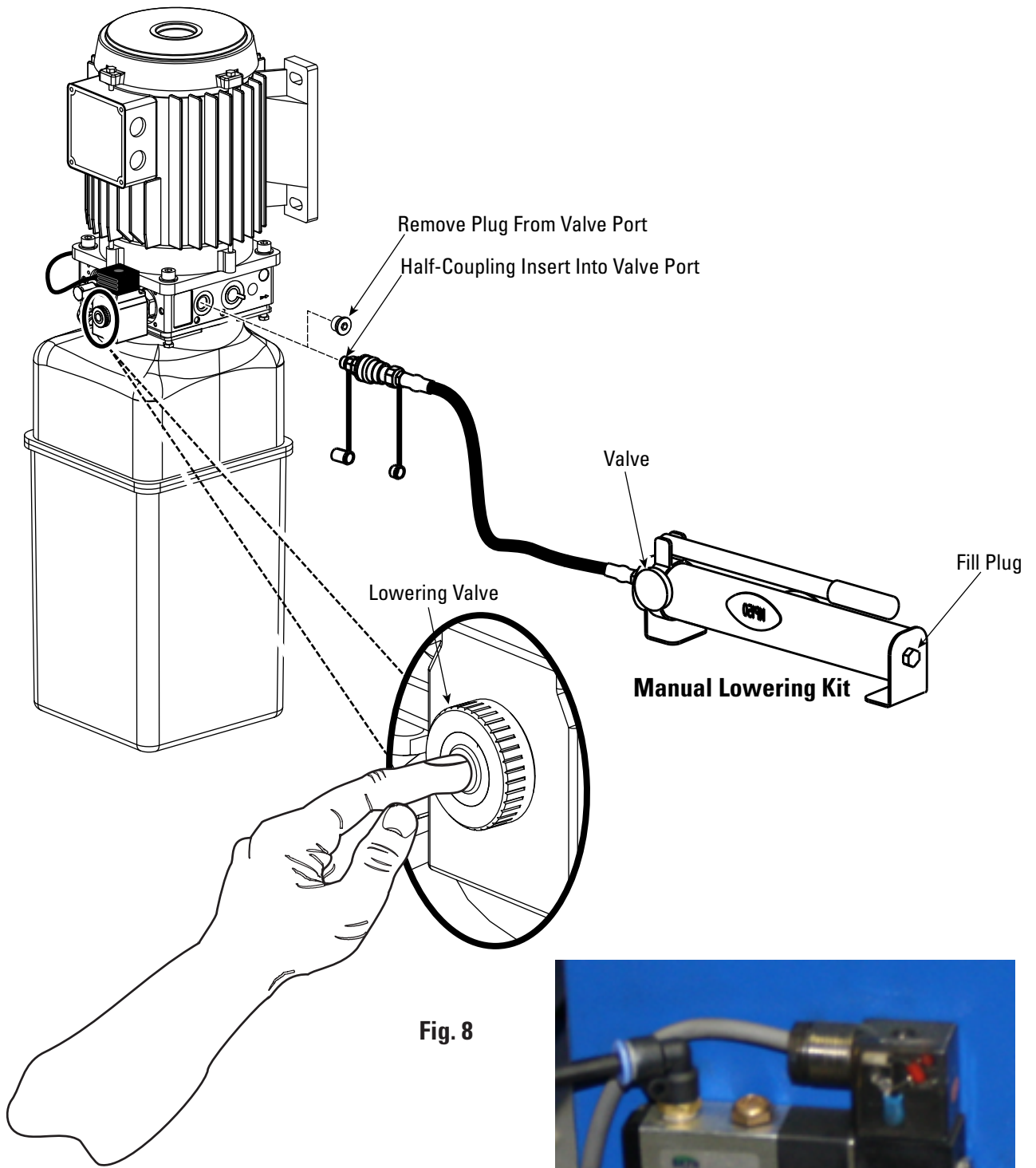

TROUBLESHOOTING

SYMPTOM 1

- 1) The lifting button is pressed, the car lift does not move and the motor does not run.

POSSIBLE CAUSE 1:

- 1A) The main switch is off.
REMEDY - Check and activate.
- 1B) Power supply is interrupted.
REMEDY - Check and activate.
- 1C) The motor contactor is faulty.
REMEDY - Check the contactor coil operation and make sure it is activated when supplied with 24V.
- 1D) Blown fuse on 24 volt power supply.
REMEDY - Check the fuse on the transformer and replace it if necessary.
- 1E) Faulty transformer.
REMEDY - Check the input and output voltage of the transformer: in. 380 V, out. 24 V.
- 1F) The motor thermo switch is activated for overheating.
REMEDY - Wait for 10 minutes and try starting again; then, using a tester, make sure the contact is closed again.

SYMPTOM 2

- 2) The lifting button is pressed, the motor runs but the car lift does not move.

POSSIBLE CAUSE 2:

- 2A) Wrong rotation direction.
REMEDY - Switch the phase and that the motor turns in the direction indicated by the arrow..
- 2B) The load to lift is too heavy, the MAX PRESSURE valve (pos. 4 picture 10) is discharged.
REMEDY - The lift is being used with an exceeding load, beyond the specified loading capacity.
- 2C) The oil level in the tank is too low.
REMEDY - Check the oil level by using the specific cap/dipstick and refill.
- 2D) Lowering valve on the hydraulic block is open.
REMEDY - Check and tighten the screws.
- 2E) The pressure valve (OM) on the block are damaged or not correct adjusted.
REMEDY - Check the pressure and replace if necessary.
- 2F) Faulty hydraulic pump.
REMEDY - Check that oil comes out from one of the outlet on the hydraulic block after disconnecting the corresponding pipe. Replace the pump if oil does not come out from the outlet.
- 2G) Blocked cylinders .
REMEDY - Contact technical assistance.

TROUBLESHOOTING

SYMPTOM 3

- 3) The lowering button is pressed but the lift does not lower.

POSSIBLE CAUSE 3:

- 3A) Make sure there are no obstacles blocking the lowering phase.

REMEDY - Remove the obstacle and carefully check the area before operating the lift.

- 3B) Make sure the main switch is on and power supply is not interrupted.

REMEDY - Check and supply power to the car lift.

- 3C) Blown fuse on the 24V power supply.

REMEDY - Check and replace the fuse after eliminating the cause of the short-circuit.

- 3D) Faulty transformer.

REMEDY - Check the input and output voltage of the transformer: in. 400 V, out. 24 V.

- 3E) Valve coil is faulty or not supplied.

REMEDY - Check whether valve is activated with 24V directed to the coil.

- 3F) Damaged or faulty valve.

REMEDY - Unscrew the valve on the hydraulic manifold and make sure it moves freely when supplied with 24 volt solenoids.

- 3G) Faulty lowering block photo switch, broken cable or improperly connected to the card

REMEDY - Check the photo switch and replace it if necessary.

SYMPTOM 4

- 4) The lift is closed but one of the two platforms is higher.

POSSIBLE CAUSE 4:

- 4A) Make sure there are no obstacles blocking the closing phase.

REMEDY - Remove the obstacle and carefully check the area before operating the lift.

- 4B) Platforms are not leveled.

REMEDY - Should this problem occur, check the car lift first, and check for bent torsion bar shaft. Contact technical assistance.

SYMPTOM 5

- 5) The lift does not stop at 250 mm from the ground but keeps lowering, producing a warning signal during the lowering phase

POSSIBLE CAUSE 5:

- 5A) Faulty or improperly installed proximity.

REMEDY - Check the proximity and replace it if necessary.

CHAPTER 8 ACCESSORIES

Available accessories:

- Drive-Through kit for surface mounted lifts;
Part # DS7000N-RMPS
- Installation frame for recess mounted lifts;
Part # DS7000i-Frame
- Transverse bars for lifting frame vehicles;
Part # DS7000-TB

Standard Colors:

- Blue (RAL5005)
- Red (RAL3002)
- Yellow (RAL1023)
- Gray (RAL7040)
- Black (RAL9005)

Special colors are available upon request.

CHAPTER 9 SPARE PARTS

Spare parts replacement and repair works should be performed in compliance with all safety rules indicated in the safety instructions.

Spare parts ordering procedure.

When ordering spare parts the following must be clearly specified:

- Car lift serial number and year of manufacturing.
- Code of the part requested (Refer to the codes in the table of the parts breakdown).
- Quantity needed.
- Spare parts must be ordered directly to the manufacturer.
- Specify the color requested,
Spare parts must be ordered directly to the manufacturer.

MAINTENANCE BOOK

INITIAL TEST

N.	DESCRIPTION TEST	YES	NO	Notes
1	Floor consistency check	<input type="checkbox"/>	<input type="checkbox"/>	<input type="checkbox"/>
2	Safety distances check (from walls, columns, ceiling, other machines etc.)	<input type="checkbox"/>	<input type="checkbox"/>	<input type="checkbox"/>
3	Power supply line check.	<input type="checkbox"/>	<input type="checkbox"/>	<input type="checkbox"/>
4	Lift levelling check.	<input type="checkbox"/>	<input type="checkbox"/>	<input type="checkbox"/>
5	Lift workingcheck.	<input type="checkbox"/>	<input type="checkbox"/>	<input type="checkbox"/>
6	Loaded lift check.	<input type="checkbox"/>	<input type="checkbox"/>	<input type="checkbox"/>
7	Lift fixing check.	<input type="checkbox"/>	<input type="checkbox"/>	<input type="checkbox"/>
8	Oil level chck.	<input type="checkbox"/>	<input type="checkbox"/>	<input type="checkbox"/>
9	Hydraulic failvre check.	<input type="checkbox"/>	<input type="checkbox"/>	<input type="checkbox"/>
10	Operating instruction	<input type="checkbox"/>	<input type="checkbox"/>	<input type="checkbox"/>

NOTES:

Client	
Stamp and signature	
Installer	
Stamp and signature	
Date	Next test on:

MAINTENANCE BOOK

INITIAL TEST

N.	DESCRIPTION TEST	YES	NO	Notes
1	Floor consistency check	<input type="checkbox"/>	<input type="checkbox"/>	<input type="checkbox"/>
2	Safety distances check (from walls, columns, ceiling, other machines etc.)	<input type="checkbox"/>	<input type="checkbox"/>	<input type="checkbox"/>
3	Power supply line check.	<input type="checkbox"/>	<input type="checkbox"/>	<input type="checkbox"/>
4	Lift levelling check.	<input type="checkbox"/>	<input type="checkbox"/>	<input type="checkbox"/>
5	Lift workingcheck.	<input type="checkbox"/>	<input type="checkbox"/>	<input type="checkbox"/>
6	Loaded lift check.	<input type="checkbox"/>	<input type="checkbox"/>	<input type="checkbox"/>
7	Lift fixing check.	<input type="checkbox"/>	<input type="checkbox"/>	<input type="checkbox"/>
8	Oil level chck.	<input type="checkbox"/>	<input type="checkbox"/>	<input type="checkbox"/>
9	Hydraulic failvre check.	<input type="checkbox"/>	<input type="checkbox"/>	<input type="checkbox"/>
10	Operating instruction	<input type="checkbox"/>	<input type="checkbox"/>	<input type="checkbox"/>

NOTES:

Client	
Stamp and signature	
Installer	
Stamp and signature	
Date	Next test on:

OCCASIONAL VISIT

N.	TEST DESCRIPTION	YES	NO	Notes
1	Lift maintenance and cleaning check.	<input type="checkbox"/>	<input type="checkbox"/>	<input type="checkbox"/>
2	Oil level check.	<input type="checkbox"/>	<input type="checkbox"/>	<input type="checkbox"/>
3	Rollers slides greasing.	<input type="checkbox"/>	<input type="checkbox"/>	<input type="checkbox"/>
4	Movable parts greasing.	<input type="checkbox"/>	<input type="checkbox"/>	<input type="checkbox"/>
5	High pressure flexible pipes check.	<input type="checkbox"/>	<input type="checkbox"/>	<input type="checkbox"/>
6	Hydraulic failure check.	<input type="checkbox"/>	<input type="checkbox"/>	<input type="checkbox"/>
7	Lift levelling check.	<input type="checkbox"/>	<input type="checkbox"/>	<input type="checkbox"/>
8	Loaded lift check.	<input type="checkbox"/>	<input type="checkbox"/>	<input type="checkbox"/>

NOTES:

Result of visit Positive
Negative

Client	
Stamp and signature	
Installer	
Stamp and signature	
Date	Next test on

OCCASIONAL VISIT

N.	TEST DESCRIPTION	YES	NO	Notes
1	Lift maintenance and cleaning check.	<input type="checkbox"/>	<input type="checkbox"/>	<input type="checkbox"/>
2	Oil level check.	<input type="checkbox"/>	<input type="checkbox"/>	<input type="checkbox"/>
3	Rollers slides greasing.	<input type="checkbox"/>	<input type="checkbox"/>	<input type="checkbox"/>
4	Movable parts greasing.	<input type="checkbox"/>	<input type="checkbox"/>	<input type="checkbox"/>
5	High pressure flexible pipes check.	<input type="checkbox"/>	<input type="checkbox"/>	<input type="checkbox"/>
6	Hydraulic failure check.	<input type="checkbox"/>	<input type="checkbox"/>	<input type="checkbox"/>
7	Lift levelling check.	<input type="checkbox"/>	<input type="checkbox"/>	<input type="checkbox"/>
8	Loaded lift check.	<input type="checkbox"/>	<input type="checkbox"/>	<input type="checkbox"/>

NOTES:

Result of visit Positive
Negative

Client	
Stamp and signature	
Installer	
Stamp and signature	
Date	Next test on

PERIODICAL OR OCCASIONAL VISIT

N.	TEST DESCRIPTION	YES	NO	Notes
1	Lift maintenance and cleaning check.	<input type="checkbox"/>	<input type="checkbox"/>	<input type="checkbox"/>
2	Oil level check.	<input type="checkbox"/>	<input type="checkbox"/>	<input type="checkbox"/>
3	Rollers slides greasing.	<input type="checkbox"/>	<input type="checkbox"/>	<input type="checkbox"/>
4	Movable parts greasing.	<input type="checkbox"/>	<input type="checkbox"/>	<input type="checkbox"/>
5	High pressure flexible pipes check.	<input type="checkbox"/>	<input type="checkbox"/>	<input type="checkbox"/>
6	Hydraulic failure check.	<input type="checkbox"/>	<input type="checkbox"/>	<input type="checkbox"/>
7	Lift levelling check.	<input type="checkbox"/>	<input type="checkbox"/>	<input type="checkbox"/>
8	Loaded lift check.	<input type="checkbox"/>	<input type="checkbox"/>	<input type="checkbox"/>

NOTES:

Result of visit Positive
Negative

Client	
Stamp and signature	
Installer	
Stamp and signature	
Date	Next test on

PERIODICAL OR OCCASIONAL VISIT

N.	TEST DESCRIPTION	YES	NO	Notes
1	Lift maintenance and cleaning check.	<input type="checkbox"/>	<input type="checkbox"/>	<input type="checkbox"/>
2	Oil level check.	<input type="checkbox"/>	<input type="checkbox"/>	<input type="checkbox"/>
3	Rollers slides greasing.	<input type="checkbox"/>	<input type="checkbox"/>	<input type="checkbox"/>
4	Movable parts greasing.	<input type="checkbox"/>	<input type="checkbox"/>	<input type="checkbox"/>
5	High pressure flexible pipes check.	<input type="checkbox"/>	<input type="checkbox"/>	<input type="checkbox"/>
6	Hydraulic failure check.	<input type="checkbox"/>	<input type="checkbox"/>	<input type="checkbox"/>
7	Lift levelling check.	<input type="checkbox"/>	<input type="checkbox"/>	<input type="checkbox"/>
8	Loaded lift check.	<input type="checkbox"/>	<input type="checkbox"/>	<input type="checkbox"/>

NOTES:

Result of visit Positive
Negative

Client	
Stamp and signature	
Installer	
Stamp and signature	
Date	Next test on

**TESTS TO BE MADE BY THE USER
TESTS DURING USE**

N.	TEST DESCRIPTION
1	Levelling check
2	Hydraulic (failure- check
3	Safety devices working check

MONTHLY TESTS

N.	TEST DESCRIPTION
1	Lift through cleaning.
2	Rollers slides greasing
3	Cylinders air bleeding(if necessary)

HALF-YEARLY TESTS

N.	TEST DESCRIPTION
1	Oil level check
2	High pressure flexible pipes check



**TESTS TO BE MADE BY THE USER
TESTS DURING USE**

N.	TEST DESCRIPTION
1	Levelling check
2	Hydraulic (failure- check
3	Safety devices working check

MONTHLY TESTS

N.	TEST DESCRIPTION
1	Lift through cleaning.
2	Rollers slides greasing
3	Cylinders air bleeding(if necessary)

HALF-YEARLY TESTS

N.	TEST DESCRIPTION
1	Oil level check
2	High pressure flexible pipes check

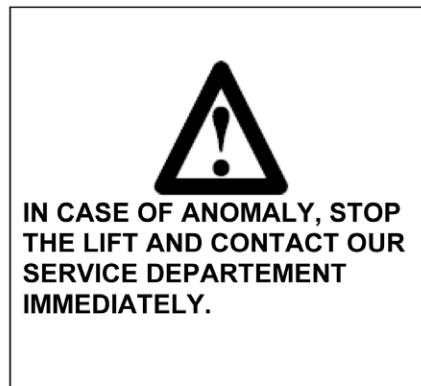

NOTES:

NOTES:

NOTES:

Vehicle Service GroupSM
2700 Lanier Drive
Madison, IN 47250, USA
1-800-640-5438
www.vsgdover.com



© **Vehicle Service GroupSM**
All Rights Reserved. Unless otherwise
indicated, **Vehicle Service GroupSM**
and all other trademarks are property
of Dover Corporation and its affiliates.