

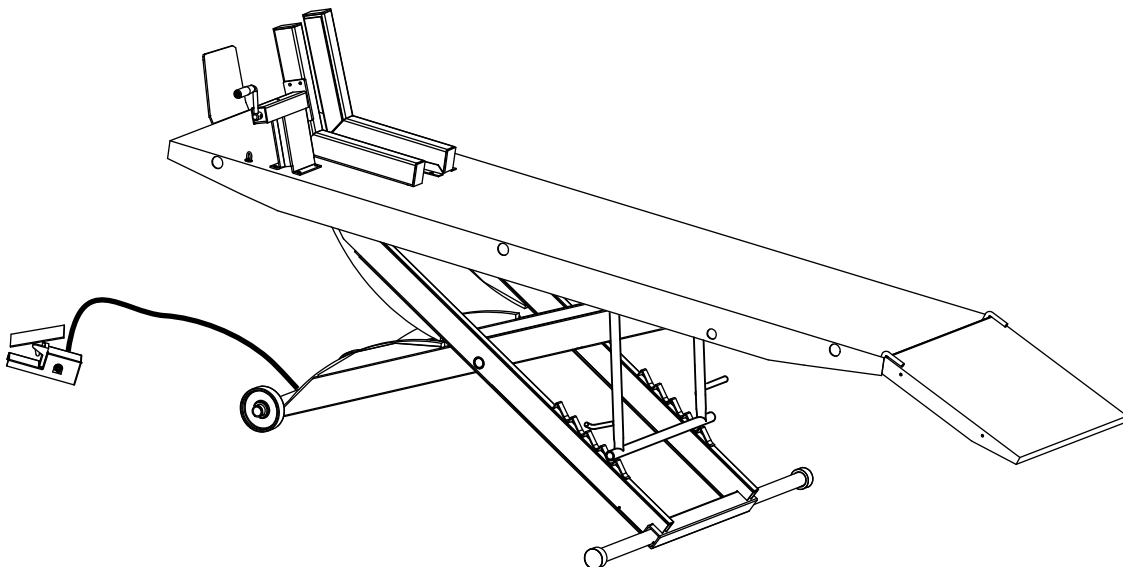

**Motorcycle Lift  
With Drop Tail  
1,000 lbs. capacity  
Installation, Safety, Operation, Maintenance**



## Inspection upon receipt of the lift

1. Always inspect the lift for freight damage and make note of any damage on the bill of lading.
2. In case of freight damage, call the truck line immediately and report the damage as a freight claim.

## Final Set-Up

This lift is more than 90% factory pre-assembled. The following steps will guide you through the final set-up. The packaged lift weighs approximately 700 lbs. While disassembling the sub components will weigh less than that, two or more people will be needed to unload and move the lift around during initial installation/unpacking of the lift.

1. Unpack the lift from the shipping skid. With the lift table up side down, connect the air hose to the air cylinder.
2. After tightening the hose to the cylinder, flip the lift over with the table surface up.
3. Connect the other end of the air hose to the foot-operated valve. Then connect the foot-operated valve to 100 PSI air supply. **DO NOT USE AIR SUPPLY WITH PRESSURE MORE THAN 100 PSI.**
4. Release the safety bar by pushing the handle down. Operate the foot valve by stepping on the footpad forward to raise the lift. The safety bar should engage the ladder automatically while lift is rising.
5. Step on the footpad again to set the pad in middle position to stop the lift when it reaches the desired height. ALWAYS LOWER LIFT IN THE NEAREST LOCKED POSITION BEFORE BEGINNING WORK. NEVER USE THE LIFT UNLESS YOU ARE IN A LOCKED POSITION.
6. Lubricating the joints again before use will ensure a better performance of the lift.
7. Vice Installation, see Fig. 1:
  - a. Install the vise clamp using (4) M8 x 20 bolts, lockwashers, and nuts.
  - b. Install the moveable vise arm into the vise clamp.
  - c. Install the fixed vise arm using (6) M8 x 20 bolts, lockwashers, and nuts.
8. Install wheel stop as shown, Fig. 1 using M8 x 20 bolts, lockwashers, and nuts.
9. Install tie down eyebolts as shown in Fig. 1 using M10 eyebolts, washers, and nuts.
10. Install the drop tail portion of the lift. Use 2 supplied detent pins to lock into place.
11. Install the approach ramp by dropping it into the holes punched on the rear edge of the table.

## XLT Installation

1. Run the Extension panel tubes through the holes on the side of the table. Install the side extensions onto the protruding tubes, Fig. 2. Use locking pins to secure the tubes, Fig. 3.
2. Drop the ramps for the side extensions in place as shown, Fig. 3. Attach using M6 x 16 bolts, lockwashers, and nuts, Fig. 3.

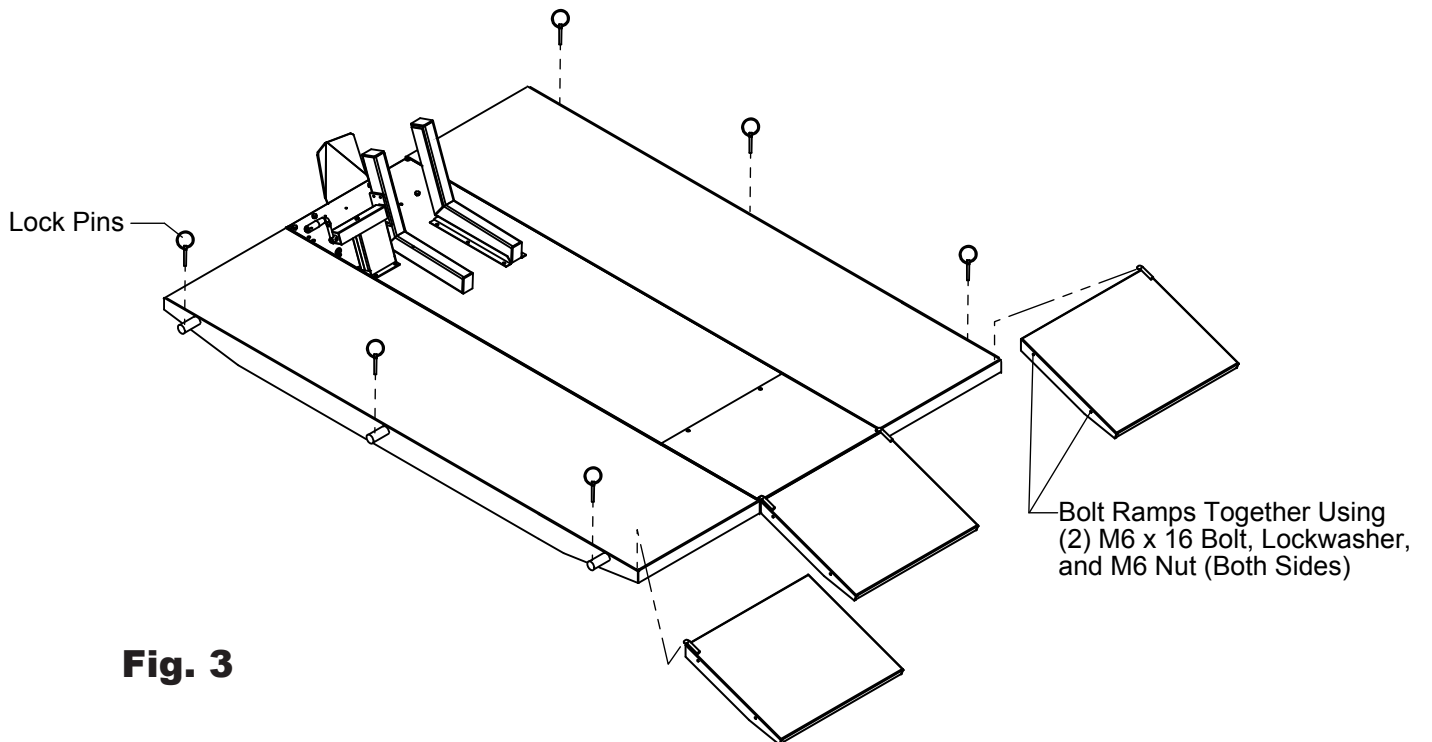
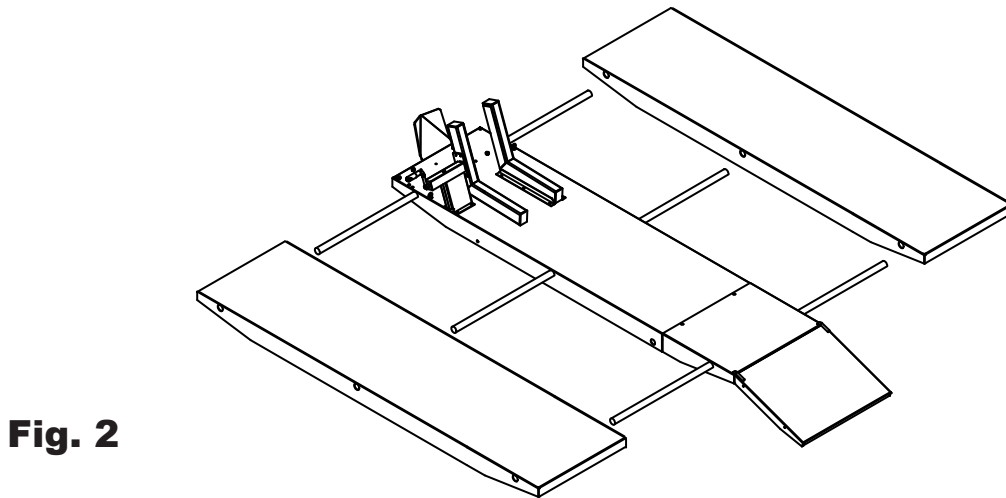
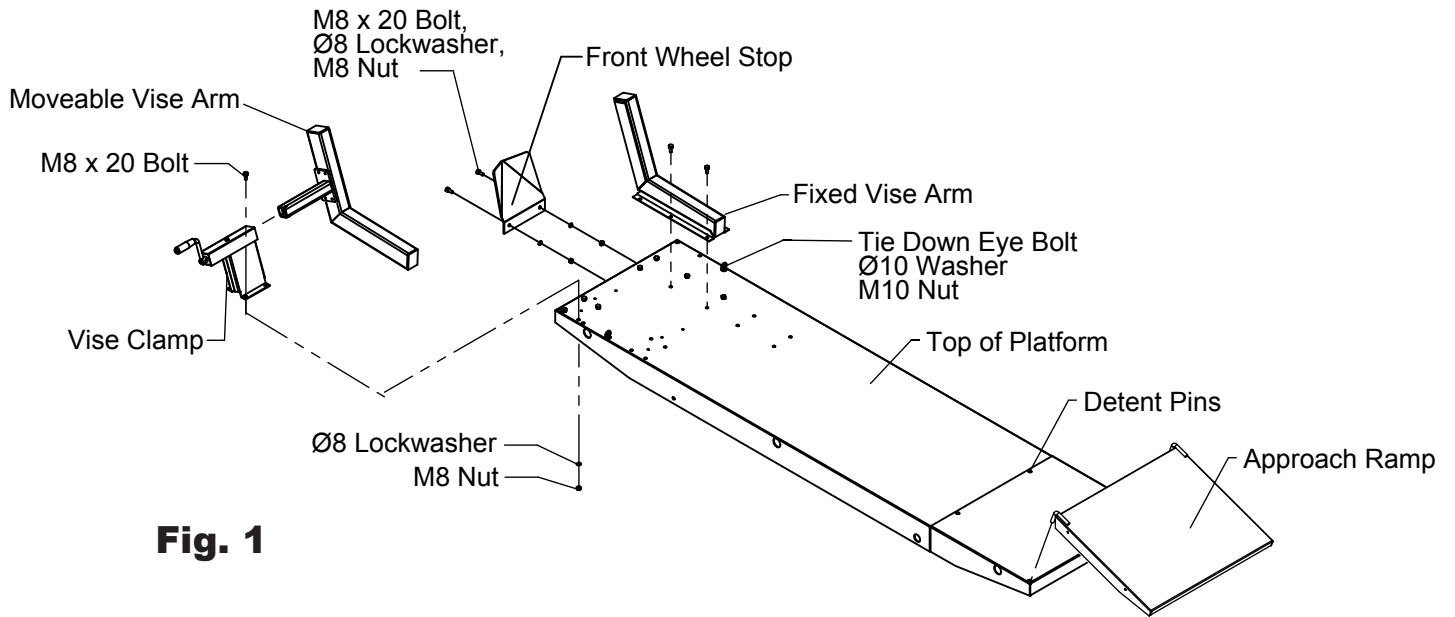

### **The Owner/Employer:**

- Shall ensure that lift operators are qualified and that they are trained in the safe use and operation of the lift using the manufacturer's operating instructions; ALI/SM01-1, *ALI Lifting it Right* safety manual; ALI/ST-90 *ALI Safety Tips* card; ANSI/ALI ALOIM-2008, *American National Standard for Automotive Lifts-Safety Requirements for Operation, Inspection and Maintenance*; ALI/WL Series, *ALI Uniform Warning Label Decals/Placards*; and in the case of frame engaging lifts, ALI/LP-GUIDE, *Vehicle Lifting Points/Quick Reference Guide for Frame Engaging Lifts*.
- Shall establish procedures to periodically inspect the lift in accordance with the lift manufacturer's instructions or ANSI/ALI ALOIM-2008, *American National Standard for Automotive Lifts-Safety Requirements for Operation, Inspection and Maintenance*; and The Employer Shall ensure that lift inspectors are qualified and that they are adequately trained in the inspection of the lift.
- Shall establish procedures to periodically maintain the lift in accordance with the lift manufacturer's instructions or ANSI/ALI ALOIM-2008, *American National Standard for Automotive Lifts-Safety Requirements for Operation, Inspection and Maintenance*; and The Employer Shall ensure that lift maintenance personnel are qualified and that they are adequately trained in the maintenance of the lift.
- Shall maintain the periodic inspection and maintenance records recommended by the manufacturer or ANSI/ALI ALOIM-2008, *American National Standard for Automotive Lifts-Safety Requirements for Operation, Inspection and Maintenance*.
- Shall display the lift manufacturer's operating instructions; ALI/SM 93-1, *ALI Lifting it Right* safety manual; ALI/ST-90 *ALI Safety Tips* card; ANSI/ALI ALOIM-2008, *American National Standard for Automotive Lifts-Safety Requirements for Operation, Inspection and Maintenance*; and in the case of frame engaging lifts, ALI/LP-GUIDE, *Vehicle Lifting Points/Quick Reference Guide for Frame Engaging Lifts*; in a conspicuous location in the lift area convenient to the operator.
- Shall provide necessary lockout/tagout means for energy sources per ANSI Z244.1-1982 (R1993), *Safety Requirements for the Lockout/Tagout of Energy Sources*, before beginning any lift repairs.
- Shall not modify the lift in any manner without the prior written consent of the manufacturer.

- Non-authorized persons or bystanders should not be around shop area while lift is in use.
- Never allow unauthorized persons to operate lift equipment.
- Thoroughly train all operators of this equipment in the use and care of lift and accessories.
- Be Sure no one is standing in front or behind lift while vehicle is being driven onto or backed off the lift.
- DO NOT permit anyone on lift or vehicle when it is either being raised or lowered.
- Always stand clear of lift when raising or lowering and observe “Pinch Points” Warnings.
- Never overload lift: capacity of lift is 1,000 lbs. CAPACITY SHOULD NEVER BE EXCEEDED!
- Before driving vehicle into lift bay, BE SURE lift is fully lowered.
- Always lower lift on locks before working on vehicle.
- Keep area around lift clean of tools, debris, grease, oil, flammables, etc.
- Replace all Caution, Warning, or Safety related decals on the lift when unable to read or missing.
- Warning children should not play on or around lift.
- Never use this lift to raise one end or one side of vehicle.
- Always lower lift completely and disconnect power source before disconnecting hydraulic lines.

## **Lift Lockout/Tagout Procedure**

### **Purpose**

This procedure establishes the minimum requirements for the lockout of energy that could cause injury to personnel by the operation of lifts in need of repair or being serviced. All employees shall comply with this procedure.

### **Responsibility**

The responsibility for assuring that this procedure is followed is binding upon all employees and service personnel from outside service companies (i.e., authorized installers, contractors, etc.). All employees shall be instructed in the safety significance of the lockout procedure by the facility owner/manager. Each new or transferred employee along with visiting outside service personnel shall be instructed by the owner/manager (or assigned designee) in the purpose and use of the lockout procedure.

### **Preparation**

Employees authorized to perform lockout shall ensure that the appropriate energy isolating device (for a dedicated compressor; lockable air valve if not) is identified for the lift being locked out. Other such

devices for other equipment may be located in close proximity of the appropriate energy isolating device. If the identity of the device is in question, see the shop supervisor for resolution. Assure that proper authorization is received prior to performing the lockout procedure.

### **Sequence of Lockout Procedure**

- 1) Notify all affected employees that a lockout is being performed and the reason for it.
- 2) Unload the subject lift. Shut it down and assure the disconnect switch is "OFF" if one is provided on the lift.
- 3) The authorized lockout person operates the main energy isolation device removing power to the subject lift.
  - If this is a lockable device, the authorized lockout person places the assigned padlock on the device to prevent its unintentional reactivation. An appropriate tag is applied stating the person's name, at least 3" x 6" in size, an easily noticeable color, and states not to operate device or remove tag.
  - If this device is a non-lockable circuit breaker or fuse, replace with a "dummy" device and tag it appropriately as mentioned above.
- 4) Attempt to operate lift to assure the lockout is working. Be sure to return any switches to the "OFF" position.
- 5) The equipment is now locked out and ready for the required maintenance or service.

### **Restoring Equipment to Service**

- 1) Assure the work on the lift is complete and the area is clear of tools, vehicles, and personnel.
- 2) At this point, the authorized person can remove the lock (or dummy circuit breaker or fuse) & tag and activate the energy isolating device so that the lift may again be placed into operation.

### **Rules for Using Lockout Procedure**

Use the Lockout Procedure whenever the lift is being repaired or serviced, waiting for repair when current operation could cause possible injury to personnel, or for any other situation when unintentional operation could injure personnel. No attempt shall be made to operate the lift when the energy isolating device is locked out.

## **Operating Conditions**

Lift is not intended for outdoor use and has an operating ambient temperature range of 41°-104°F (5°-40°C).

**Observe and heed SAFETY, CAUTION and WARNING labels on the lift.**

1. Lift must be fully lowered and service bay clear of all personnel before the vehicle is brought on lift.

**2. Motorcycle Loading:**

- A. Put motorcycle onto lift. Be sure motorcycle is centered on lift from side to side.
- B. Stop when motorcycle front wheel is in wheel clamp/stop.
- C. Secure motorcycle to lift using clamps and straps.

**4. To Raise Lift:**

- A. Release lock handle from lift.
- B. Actuate raise button on foot pedal.
- C. Raise to desired height. Note: lock should be clicking into place as lift is raised. If not, stop. Lower lift to ground then repeat entire step 4.
- D. Actuate lower button on foot pedal and lower lift onto locks.

**CAUTION** DO NOT go under lift or vehicle if locking latches are not engaged.

**6. While Using Lift:**

- A. Avoid excessive rocking of vehicle while on lift.
- B. Using supplied cycle jack, the drop tail portion of the lift can be removed allowing for clear access to rear wheel service.

**7. To Lower Lift:**

- A. Remove all tools or other objects from lift area.

**IMPORTANT** Ensure drop tail is properly secured back onto lift using supplied detent pins.

- B. Actuate raise button on foot pedal to raise lift off locking latches.
- C. Rotate lock back up under lift and lock into place.
- D. Actuate lowering button on foot pedal to lower.

8. Remain clear of lift when lowering vehicle. Observe pinch points.

9. Remove motorcycle from lift.

10. If lift is not operating properly, **Do Not** use until adjustment or repairs are made by qualified lift service personnel.

**⚠ WARNING** If you are not completely familiar with automotive lift maintenance procedures **STOP**: Contact factory for instructions.

To Avoid Personal Injury, permit only qualified lift service personnel to perform maintenance on this equipment.

**Use only genuine Direct replacement parts for repairs.**

- **Always** keep all bolts tight. Check periodically.
- **Always** raise lift when cleaning floor area.
- **Always** keep lift clean.
- **Daily**: Inspect for damage or excessive wear. Replace as required with genuine Direct parts.
- **Daily**: Check locking latch operation.
- **Weekly**: Inspect all lift parts for signs of damage due to overloading and rough handling.
- **Monthly**: Lubricate hinge joints paying extra attention to all locations with zerk fittings.
- **Replace** all CAUTION, WARNING, or SAFETY related decals on the lift if unable to read or missing. Reorder labels from Direct lift.

<p><b>⚠ CAUTION</b></p>  <p>Lift to be used by trained operator only.</p>	<p>Power Unit: Secure placard near lift controls.</p>  <p>Lift Control Console: Secure placard in an accessible location.</p>	<p>The messages and pictographs shown are generic in nature and are meant to generally represent hazards common to all automotive lifts regardless of specific style.</p> <p>Funding for the development and validation of these labels was provided by the Automotive Lift Institute, PO Box 33116, Indialantic, FL, 32903-3116.</p> <p>They are protected by copyright. Set of labels may be obtained from ALI or its member companies.</p> <p>© 1992 by ALI, Inc. ALI/WL300csw</p>
<p><b>⚠ CAUTION</b></p>  <p>Authorized personnel only in lift area.</p>	<p><b>⚠ CAUTION</b></p>  <p>Use vehicle manufacturer's lift points.</p>	<p><b>⚠ CAUTION</b></p>  <p>Always use safety stands when removing or installing heavy components.</p>
<p><b>SAFETY INSTRUCTIONS</b></p>  <p>Read operating and safety manuals before using lift.</p>	<p><b>SAFETY INSTRUCTIONS</b></p>  <p>Proper maintenance and inspection is necessary for safe operation.</p>	<p><b>SAFETY INSTRUCTIONS</b></p>  <p>Do not operate a damaged lift.</p>

### SAFETY WARNING LABELS FOR HINGED FRAME ENGAGING LIFTS

Lift Owner/User Responsibilities:

A. This Safety Warning placard **SHALL** be displayed in a conspicuous location in the lift area.

B. Use one of the mounting arrangements illustrated on back of this placard.

C. These Safety Warning labels supplement other documents supplied with the lift.

D. Be certain all lift operators read and understand these labels, operating instructions and other safety related information supplied with the lift.

<p><b>⚠ WARNING</b></p>  <p>Position vehicle with center of gravity midway between adapters.</p>	<p><b>⚠ WARNING</b></p>  <p>Remain clear of lift when raising or lowering vehicle.</p>	<p><b>⚠ WARNING</b></p>  <p>Keep feet clear of lift while lowering.</p>
<p><b>⚠ WARNING</b></p>  <p>Clear area if vehicle is in danger of falling.</p>	<p><b>⚠ WARNING</b></p>  <p>Avoid excessive rocking of vehicle while on lift.</p>	<p><b>⚠ WARNING</b></p>  <p>Keep clear of pinch points when lift is moving.</p>



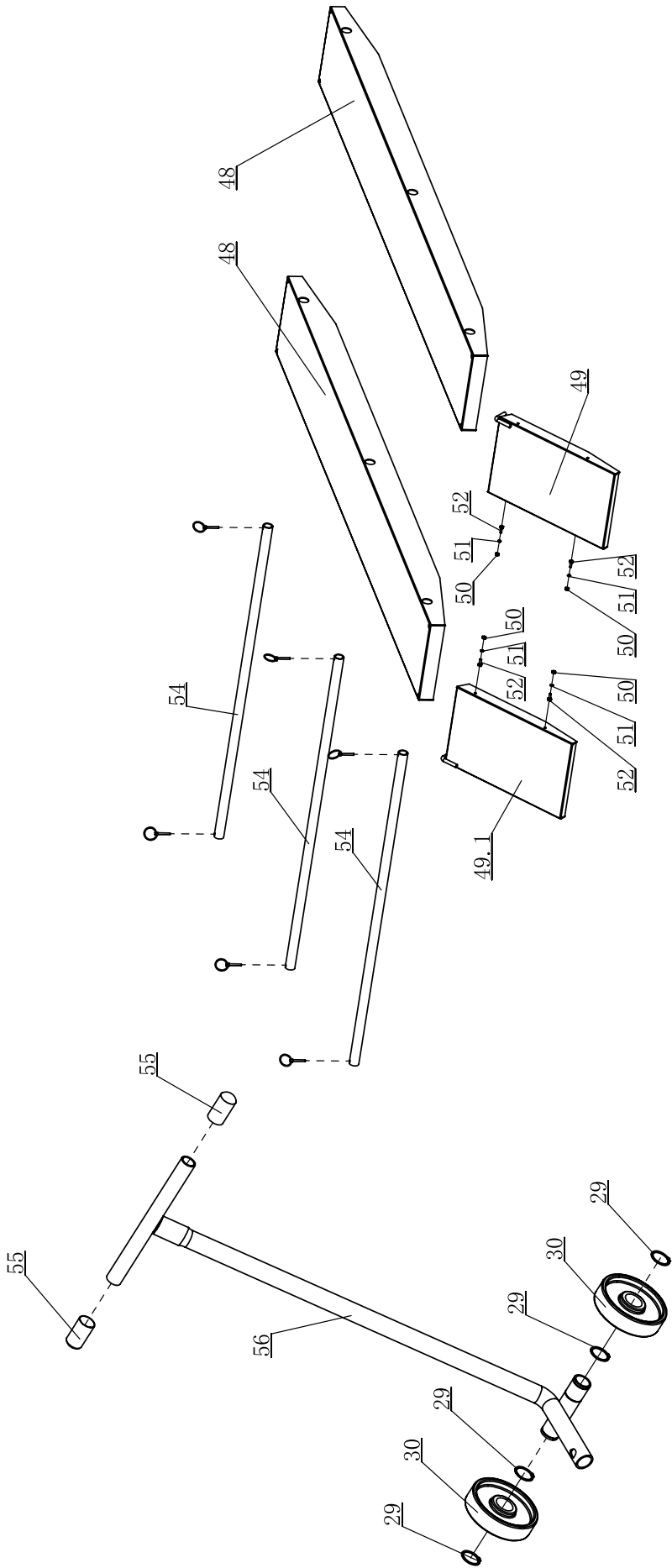

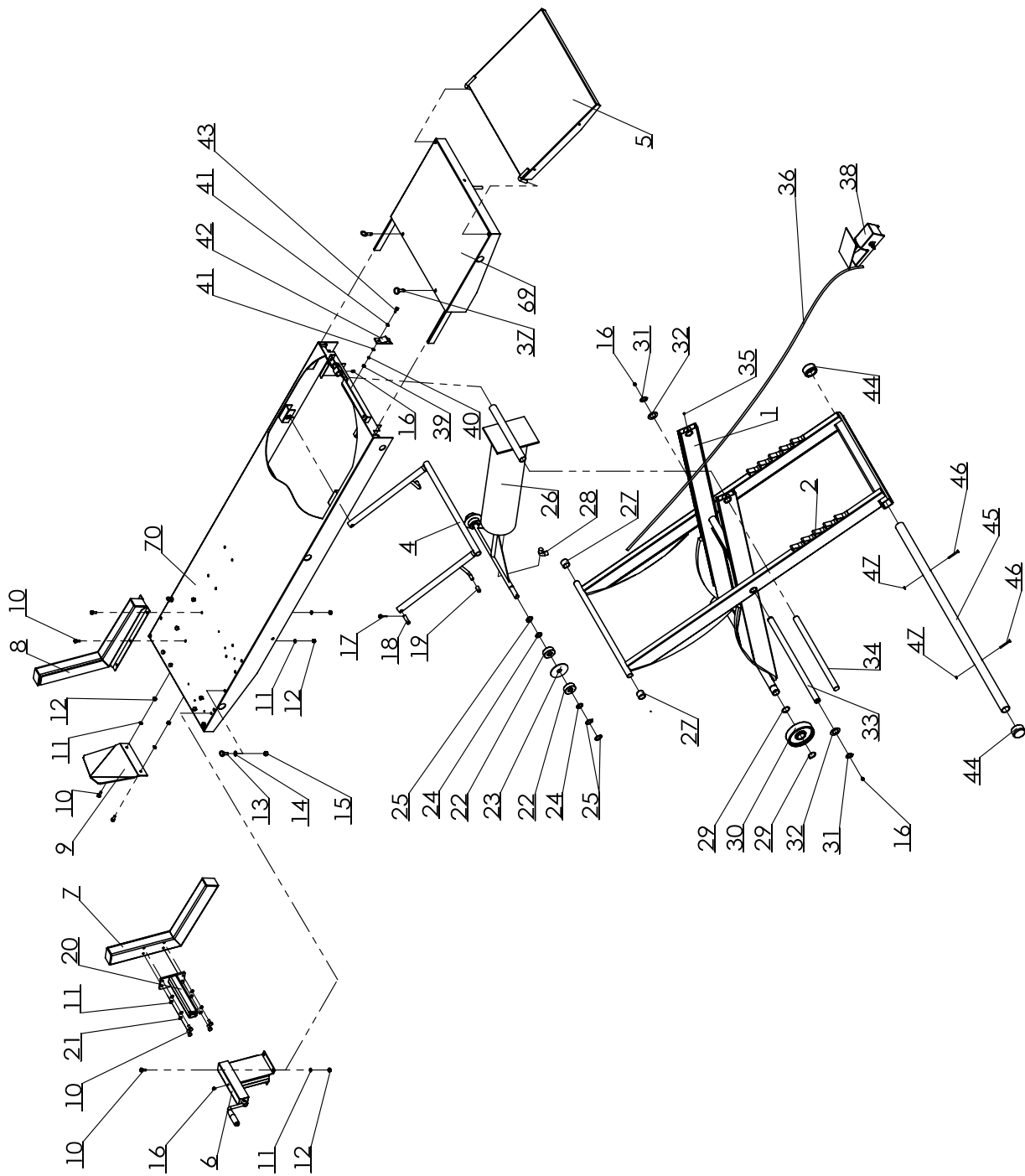

Item	Part Number	Description	Qty
1	AL-1000	Scissor A-Outside	1
2	AL-2000	Scissor B-Inside	1
4	AL-4000	Lock Bar	1
5	AL-5202	Center,Approach Ramp B	1
6	AL-5400	Vise Clamp Handle-Assy	1
7	AL-5302	Vise,Moving Jaw-Assy	1
8	AL-5301	Vise,Stationary Jaw	1
9	AL-5604	Wheel Stop	1
10	B10-8×20	Bolt M8×20	16
11	B40-8	Lock Washer Ø8	16
12	B30-8	Nut M8	12
13	B27-10×20	'Tie Down" Eye Bolt M10×20	2

14	B41-10	Flat Washer Ø10	2
15	B30-10	Nut M10	2
16	B85-6	Grease Zerk M6	5
17	B52-3×30	Cotter Pin Ø3×30	2
18	B53-12×45	Pin (B)Ø12×45	2
19	AL-4004	Plastic Grip	2
20	AL-5303	Moveable Vise Extension	1
21	B41-10	Flat Washer Ø8	4
22	AL-6006	Wheel	4
23	AL-6004	Washer	2
24	B41-18	Flat Washer Ø18	4
25	B60-19	C-clip Ø19	6
26	YG09-9100	Air Cylinder	1
27	AL-6007	Bearing/Scissor	2
28	YG09-9106	Fitting	1
29	B60-32	Spacer Ø32	8
30	AL-5501	Wheel	4
31	B60-25	Spacer Ø25	2
32	AL-6005	Washer	2
33	AL-6003	Shaft/Scissor pivot	1
34	AL-6002	Shaft/Scissor pivot	1
35	B21-6×8	Set Screw M6×8	2
36	YG09-9301	Air Hose	1
37	ALG-2010	Detent Pin	2
38	YG09-9300G	Foot-Operated Valve	1
39	B30-5	Nut M5	1
40	B40-5	Lock Washer Ø5	1
41	B41-5	Flat Washer Ø5	2
42	AL-6001	Lock Bar Holder	1
43	B10-5×16	Bolt M5×16	1
44	AL-5603	End Cap,Stabilizing Tube	2
45	AL-5602	Stabilizing Tube	1
46	B10-6×50	Bolt M6×50	2
47	B30-6	Nut M6	2
48	AL-5101	Side Extension	2
49	AL-5201	XLT Approach Ramp,Left Side EXT	1
49.1	AL-5201DC	XLT Approach Ramp,Left Side EXT	1
50	B30-6	Nut M6	6
51	B40-6	Lock Washer Ø6	4
52	B10-6×16	Bolt M6×16	4
53	AL-5605	Lock Clip Pins	6
54	AL-5601	Extension Panel Tube	3
55	B81-26	Plastic Handle Grip Ø26.8/Dolly	2
56	AL-5510	Dolly	1
69	ALG-2000	Extension Table	1
70	ALG-1000	Lift Table	1

## WARRANTY POLICY

- **Two Post/Four Post, Vehicle and Specialty Lifts** weight capacity models 7,000 lbs. through 14,000 lbs. are warranted for (5) years on structural components and (2) years on hydraulic power units and cylinders from invoice date.
- **Low Rise and Mid Rise Lifts** weight capacity models 6,000lb are warranted for (2) years on structural components and (2) years on hydraulic power units and cylinders from invoice date.
- **Rotisserie units, Motor Cycle Lifts, Jacks, Lift Accessories, Jack Stands and Lift Kits, etc.** are warranted for (1) year on structural components and (1) year on air / hydraulic power units, pneumatic cylinders and components from invoice date.

**NOTE: ALL WARRANTY CLAIMS MUST BE PRE-APPROVED BY THE MANUFACTURER TO BE VALID.**

The Manufacturer shall repair or replace at their option for this period those parts returned to the factory freight prepaid, which prove after inspection to be defective. This warranty will not apply unless the product is installed, used and maintained in accordance with the Manufacturers installation, operation and maintenance instructions.

This warranty applies to the ORIGINAL purchaser only, and is non-transferable. The warranty covers the products to be free of defects in material and workmanship but, does not cover normal maintenance or adjustments, damage or malfunction caused by: improper handling, installation, abuse, misuse, negligence, carelessness of operation or normal wear and tear. In addition, this warranty does not cover equipment when repairs or alterations have been made or attempted to the Manufacturer's products.

THIS WARRANTY IS EXCLUSIVE AND IS LIEU OF ALL OTHER WARRANTIES EXPRESSED OR IMPLIED INCLUDING ANY IMPLIED WARRANTY OR MERCHANTABILITY OR ANY IMPLIED WARRANTY OF FITNESS FROM A PARTICULAR PURPOSE, AND ALL SUCH IMPLIED WARRANTIES ARE EXPRESSLY EXCLUDED.

THE REMEDIES DESCRIBED ARE EXCLUSIVE AND IN NO EVENT SHALL THE MANUFACTURER, NOR ANY SALES AGENT OR OTHER COMPANY AFFILIATED WITH IT OR THEM, BE LIABLE FOR SPECIAL CONSEQUENTIAL OR INCIDENTAL DAMAGES FOR THE BREACH OF OR DELAY IN PERFORMANCE OF THIS WARRANTY. THIS INCLUDES, BUT IS NOT LIMITED TO, LOSS OF PROFIT, RENTAL OR SUBSTITUTE EQUIPMENT OR OTHER COMMERCIAL LOSS.

This warranty shall be governed under the laws of Indiana, and shall be subject to the exclusive jurisdiction of the Court in the State of Indiana in the county of Jefferson.

**PRICES:** Prices and specifications are subject to change without notice. All orders will be invoiced at prices prevailing at time of shipment. Prices do not include any local, state or federal taxes.

**RETURNS:** Products may not be returned without prior written approval from the Manufacturer.

DUE TO THE COMPETITIVENESS OF THE SELLING PRICE OF THESE LIFTS, THIS WARRANTY POLICY WILL BE STRICTLY ADMINISTERED AND ADHERED TO.

Rev 01/08/2008