

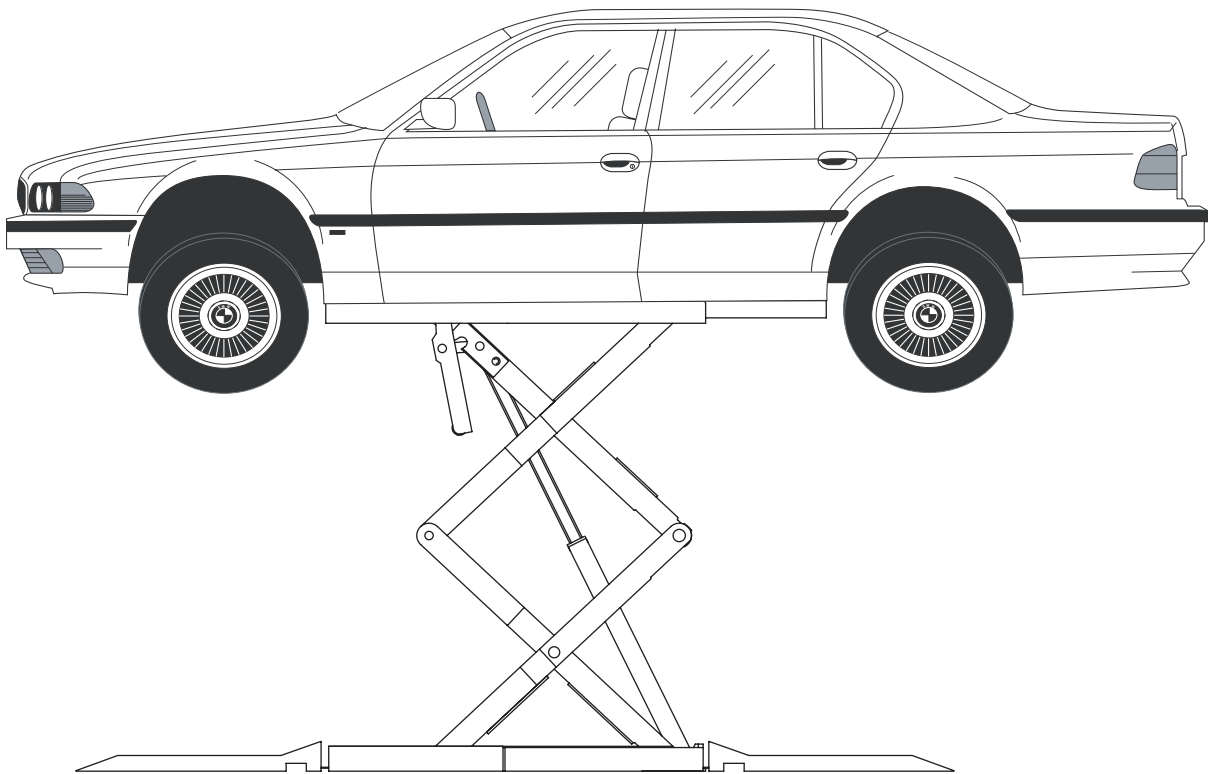

# RLP35 Scissor Lift (300 Series)

Capacity 7700 lbs (3500 kg)  
(Maximum 3,850 lbs (1750 kg) per pad)



P  
A  
R  
T  
S  
  
B  
R  
E  
A  
K  
D  
O  
W  
N

**OWNERS RECORD**  
Complete information  
at right and keep in  
a safe place.

Date Installed \_\_\_\_\_

Installed in Bay # \_\_\_\_\_

Power Unit Serial # \_\_\_\_\_

Power Unit Model # \_\_\_\_\_

Lift Serial # \_\_\_\_\_

Lift Model # \_\_\_\_\_

**NOTE: For replacement parts -See your nearest Rotary Parts Distributor.**

**PB 2-8-1**

Rev. F 06/08/2010

Base Detail			
Item	Qty.	Description	Part Number
1	2	Floating Bearing, Top Right	XG120048
2	2	Floating Bearing, Top Left	XG120047
3	4	Bearing Plate	XG120049
4	2	Bolt	XG120042
5	4	Bearing Sleeve	XG130004
6	4	Groove Nut	XG130007
7	4	Bolt	XG120077
8	4	Threaded Pin	XG130044
9	4	Bushing	XG130009
10	4	Bolt	XG120080
11	NA	NA	NA
12	4	Groove Nut	XG130007
13	8	Bushing	XG130010
14	4	Bolt	XG120080
15	4	NA	NA
16	4	Groove Nut	XG130007
17	4	Bushing	XG130010
18	4	Bolt	XG120082
19	4	Groove Nut	XG130007
20	8	Bushing	XG130010
21	4	Bolt	XG120080
22	4	Bushing	XG130006
23	4	Groove Nut	XG130007
24	4	Bushing	XG130004
25	2	Floating Bearing, Bottom, Right	XG120046
26	2	Floating Bearing, Bottom, Left	XG120045
27	4	Bolt	XG120077
28	4	Threaded Pin	XG130044
29	4	Bushing	XG130009
30	4	Bushing	XG130003
31	2	Cylinder Stud	XG120044
32	4	Flanged Wheel	XG120041
33	4	Bushing	XG130005
34	8	Bushing	XG130008
35	NA	NA	NA
36	4	Bushing, Rolled	XG130004
37	4	Bolt	XG120043
38	4	Castor	XG120037
39	4	Bushing	XG130076
40	4	Groove Nut	XG130007
41	4	Bolt	XG120099
42	16	Bushing	XG130009
43	4	Threaded Pin	XG130044

44	2	Hydraulic Cylinder (Master)	XG130001
45	2	Hydraulic Cylinder (Slave)	XG130002
46	2	Cylinder Cover	XG120094
47	4	Flat Head Screw	XG130046
48	1	M6 BHCS	XG130055
49	2	Underframe	XG120001
50	2	Upperframe	XG120014
51	1	Pullout, Left	XG120030
52	1	Pullout, Right	XG120035
53	1	Cylinder Screw	XG120029
54	2	Circular Blank	XG120028
55	2	Inner Scissors, Bottom	XG120050
56	2	Outer Scissors, Bottom	XG120055
57	2	Inner Scissors, Top	XG130061
58	2	Outer Scissors, Top	XG120071
59	4	Lever Arm	XG120036
60	2	Cylinder Lever	XG120038
61	4	Ramp 300	XG120086
62	4	Ramp 1000	XG120091
63	2	Underfloor Box	XG120108
64	4	Rubber Block With Diamond Pattern	FJ2427 FJ2428
65	2	Hose Covering	XG120096
66	1	Hose Covering	XG120095
67	2	Flow Control Valve Assembly	XG120112
68	2	Master Cylinder Seal Kit	XG140007
69	2	Slave Cylinder Seal Kit	XG140008
	3	Proximity Switch (Not Shown)	XG130075

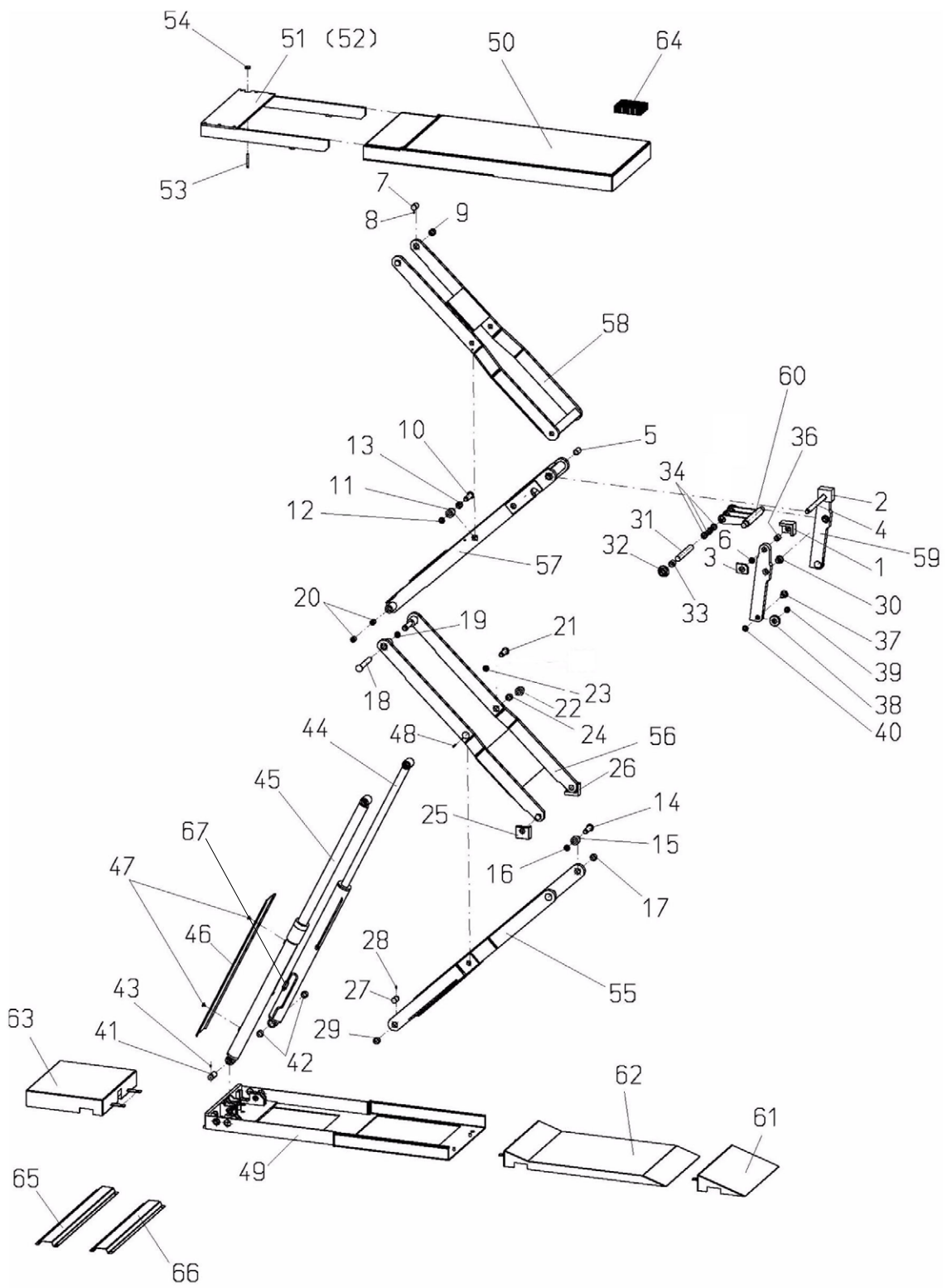

Controls			
Item	Qty.	Description	Part Number
1	1	Control Column	XG150084
2	1	Bolt M4 BHCS	
3	1	Power Unit	
		3 Phase 50-60 Hz. / 208-460V	P3555
		1 Phase 60 Hz. / 208-230V	P3553
		1 Phase 50 Hz. / 220V	P3554
		3 Phase 50 Hz. / 380-400V	P3562
4	2	Bolt	XG150079
5	2	Lock Washer	XG150074
6	1	Control Panel	
		1 Phase	XG150086
		3 Phase 230/460V	XG150085-3U
		3 Phase 400V	XG150085-3E
		3 Phase 230V	XG150085-3EL
7	1	Control Board	
		1 Phase	PCB-3
		3 Phase 230/460V	PCB-2
		3 Phase 400V	PCB-1
		3 Phase 230V	PCB-1L
8	1	Disconnect	XG150046
9	1	Power Lamp	XG150038
10	1	UP Push Button	XG150124
11	1	DOWN Push Button	XG150035
12	1	Transformer	XG150044

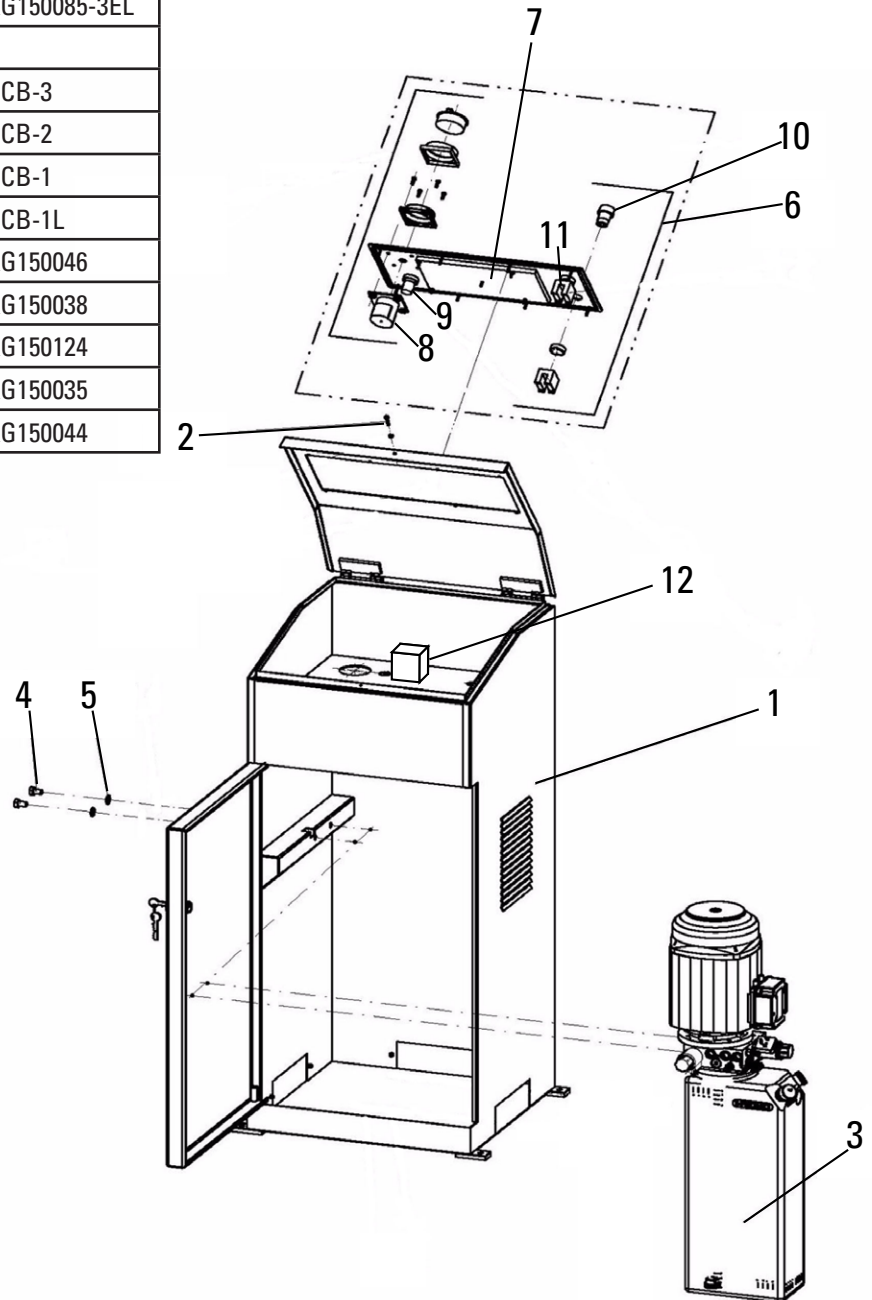

Hydraulic Parts		
Qty.	Description	Part Number
2	T-Piece	XG130018
1	Hydraulic Hose L= 4930mm Designation "B1"	XG130012
1	Hydraulic Hose L= 4280mm Designation "B2-E2"	XG130013
1	Hydraulic Hose L= 4280mm Designation "A2-E1"	XG130087
1	Hydraulic Hose L= 4930mm Designation "A1"	XG130088
2	Hydraulic Hose <b>L=800mm</b> Designation "E"	XG130016
2	Hydraulic Hose L= 2250mm Designation "F"	XG130089
Optional Hydraulic Parts		
Qty.	Description	Part Number
4	1/4" BSPP Union	XG130038
1	Hydraulic Hose L= 3000mm Designation "B1"	XG130081
1	Hydraulic Hose L= 3000mm Designation "B2"	XG130082
1	Hydraulic Hose L= 3000mm Designation "A2"	XG130083
1	Hydraulic Hose L= 3000mm Designation "A1"	XG130084

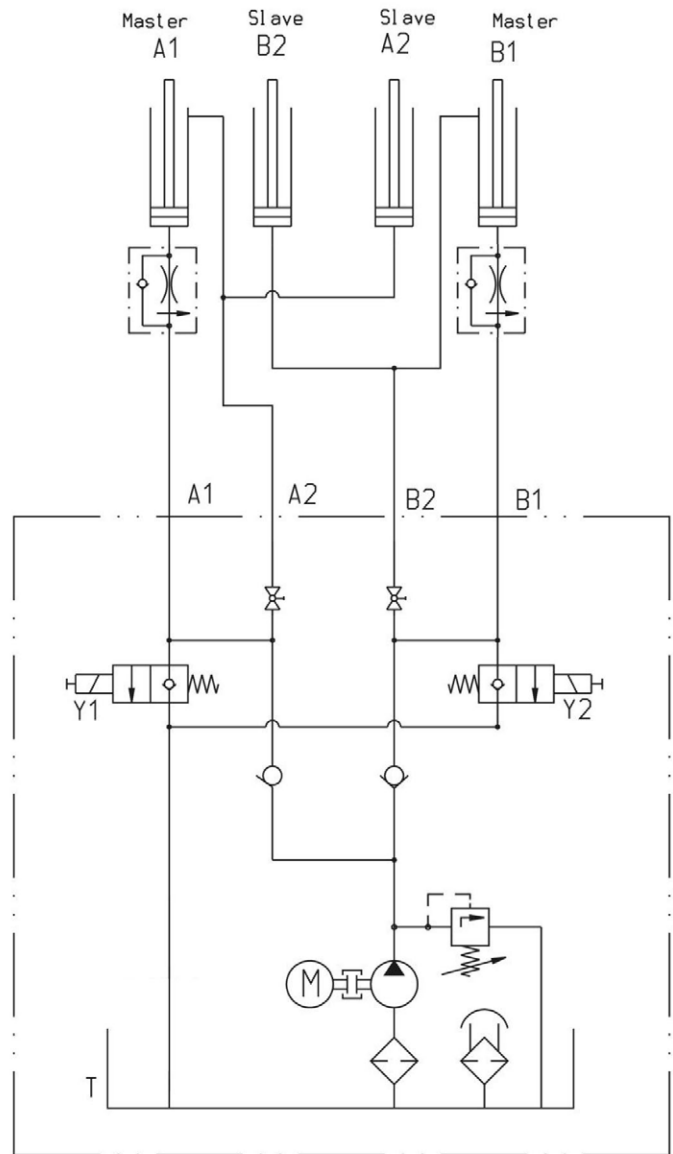

## NOTES



---

**Rotary World Headquarters**

2700 Lanier Drive  
Madison, IN 47250, USA  
[www.rotarylif.com](http://www.rotarylif.com)

**North America Contact Information**

Tech. Support: p 800.445.5438  
f 800.578.5438  
e [userlink@rotarylif.com](mailto:userlink@rotarylif.com)  
Sales: p 800.640.5438  
f 800.578.5438  
e [userlink@rotarylif.com](mailto:userlink@rotarylif.com)

**World Wide Contact Information**

World Headquarters/USA: 1.812.273.1622  
Canada: 1.905.812.9920  
European Headquarters/Germany: +49.771.9233.0  
United Kingdom: +44.178.747.7711  
Australasia: +60.3.7660.0285  
Latin America / Caribbean: +54.3488.431.608  
Middle East / Africa: 1.812.273.1622

© Rotary®, Printed in U.S.A., All Rights Reserved. Unless otherwise indicated, ROTARY, DOVER and all other trademarks are property of Dover Corporation and its affiliates.



A  DOVER™ COMPANY

